

# Interior Multi-Camera

---

## Installation Manual

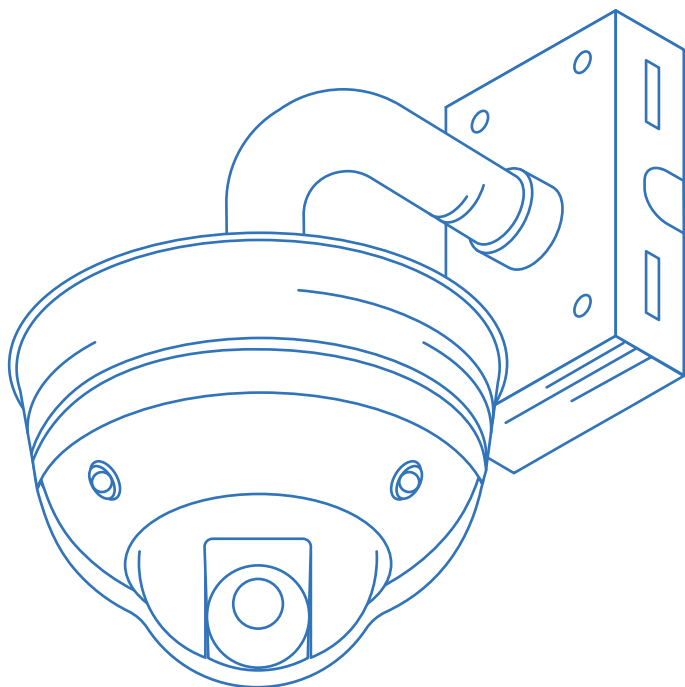

# Assembled Unit

---

*Tripod not included.*

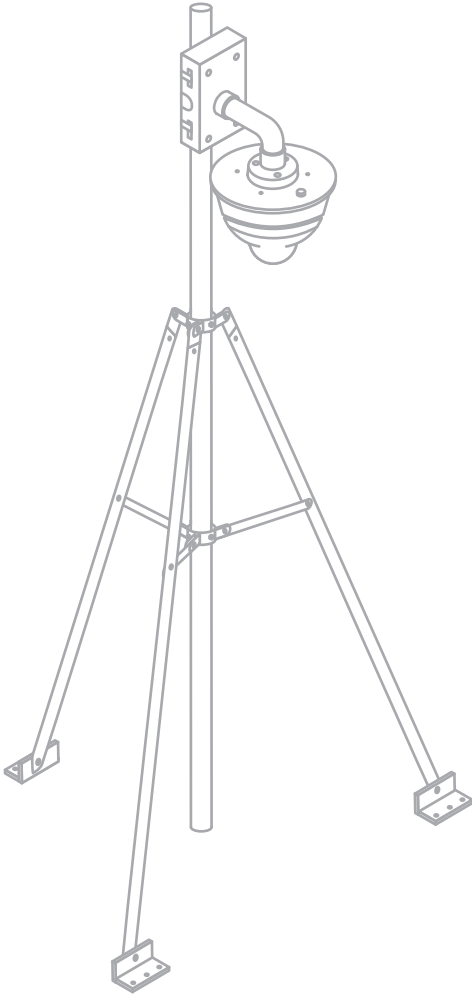

# Unlimited Support

---

If you have any questions or issues with your TrueLook system, please don't hesitate to contact our Customer Support team.

**Phone** 833-878-3566 (Option 2)

**Email** [support@truelook.com](mailto:support@truelook.com)

You can also submit a support request online at:

[support.truelook.com/contact-support](https://support.truelook.com/contact-support)

# Online Resources

---

Scan this QR code or visit [truelook.com/install](https://truelook.com/install) to access:

- ✓ A guide to administrative settings and time-lapse setup.
- ✓ Video demonstrations of installation procedures.
- ✓ Digital versions of all installation manuals.
- ✓ And more!



For Terms & Conditions, as well as Warranty information, visit: [truelook.com/terms-conditions](https://truelook.com/terms-conditions).

# Hardware Packing List

---

Camera and Pendant Mount [1x]

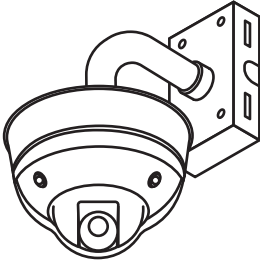

40" Steel Straps [2x]



20' 110V Power Cord [1x]

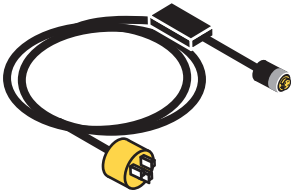

Assorted Hardware

Zip Ties [4x]



### Tripod Mount Kit [1x]

*Only included with tripod order.*

---

Tripod [1x]

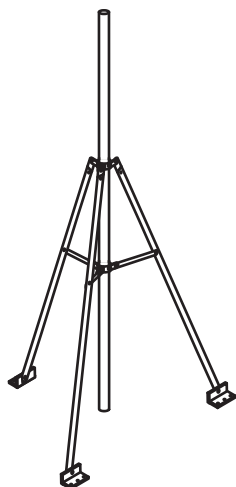

Bolts [6x]

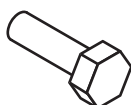

Square Nuts [6x]



Hex Nuts [6x]



### Ceiling Mount Kit [1x]

*Only included with ceiling mount order.*

---

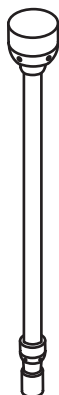

# Preparing for Installation

**Warning:** A correctly assembled interior camera will have a gap around the top rim. Do not attempt to close or otherwise tamper with the gap.

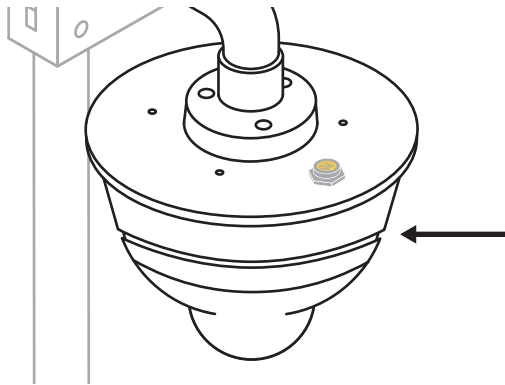

## Determine Mounting Hardware

### Wall Mounting

Your mounting kit **does not include** hardware for wall mounting. Choose appropriate mounting hardware for your surface.

## Pole Mounting

---

**Step 1** Thread steel straps through top and bottom of pendant mount.

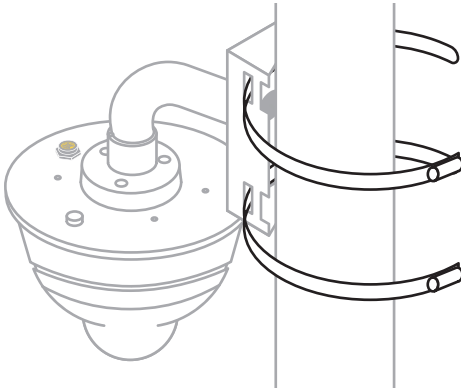

**Step 2** Tighten each strap around pole using a drill with a 5/16 hex head driver bit (not included).

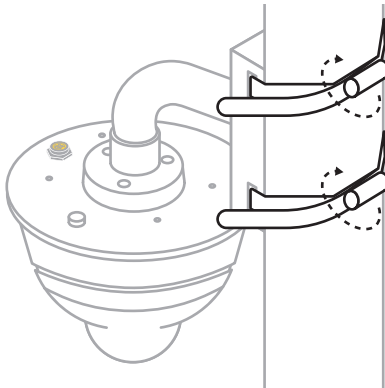

# Installation

**Step 3** Trim steel straps to desired length using tin snips (not included).

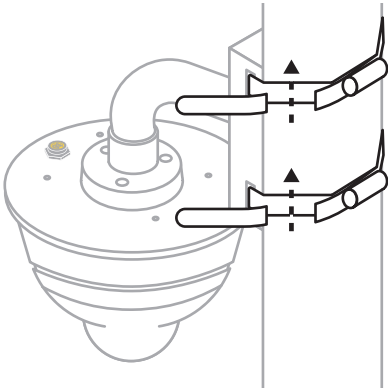



## Wall Mounting

---

**Step 1** Using chosen hardware (see “Preparing for Installation” section), secure pendant mount to wall.

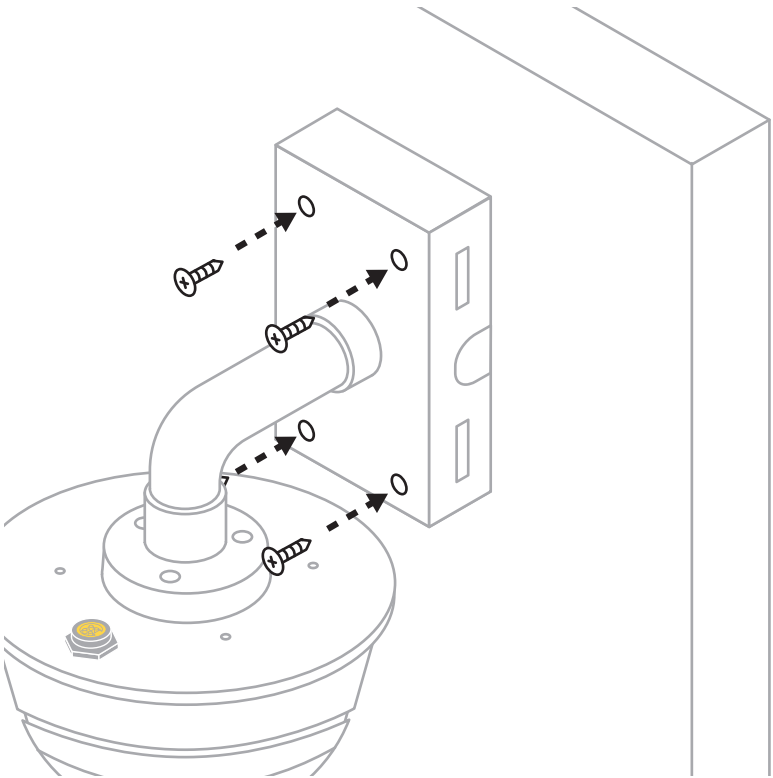

# Tripod Mounting

---

**Step 1** Extend legs of tripod and remove protective wrapping.

**Step 2** Thread hex nut onto bolt, then hand thread hardware into upper center circle of tripod. Thread square nut onto bolt end on inside of circle.

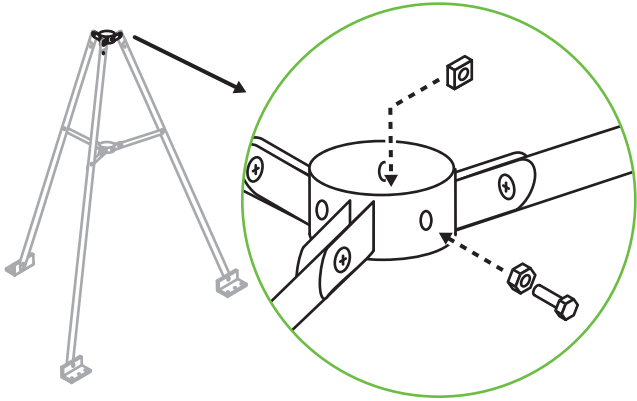

**Step 3** Repeat step 2 with other two sets of hardware, then repeat with lower center circle.

**Step 4** Slide mounting pole through center holes of tripod.

**Step 5** Follow pole mounting instructions (page 7).

**Step 6** Extend pole to desired height.

*Note: Pole should not be raised above lower center circle of tripod.*

**Step 7** Tighten bolts to clamp down on pole evenly using a ½” wrench or socket (not included).

**Step 8** Move tripod to desired area and secure feet.

**Warning:** It is your responsibility to secure the tripod properly to ensure it does not fall over. We suggest securing the feet to the floor or a pallet with lag bolts (not included) or weighing them down with ballast material like sandbags or cinder blocks.

# Powering the System

**Step 1** Locate yellow connector port on top of camera.

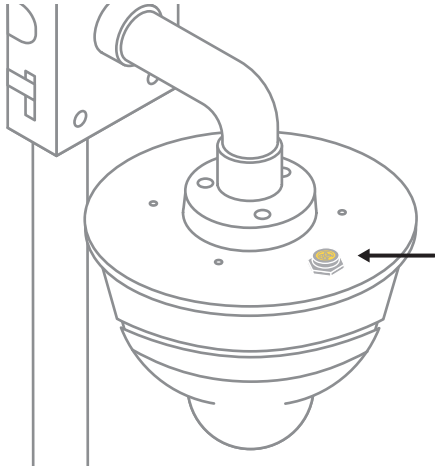

**Step 2** Align notches and plug end of 110V cable into port.

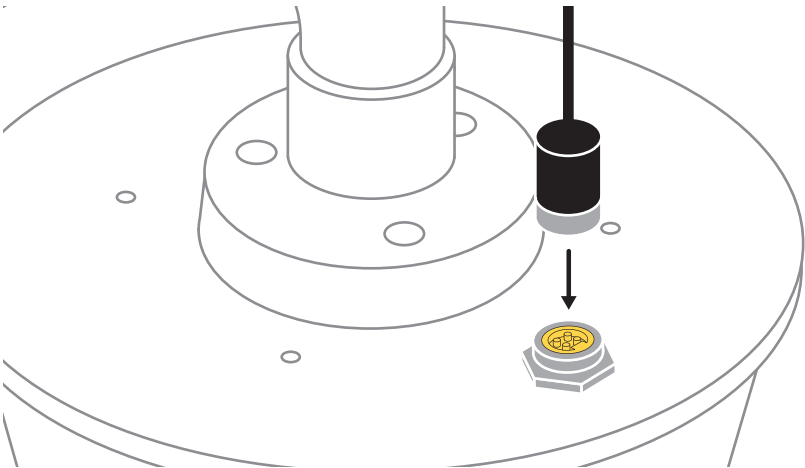

**Step 3** Gently hand tighten silver collar to secure cable end into input.

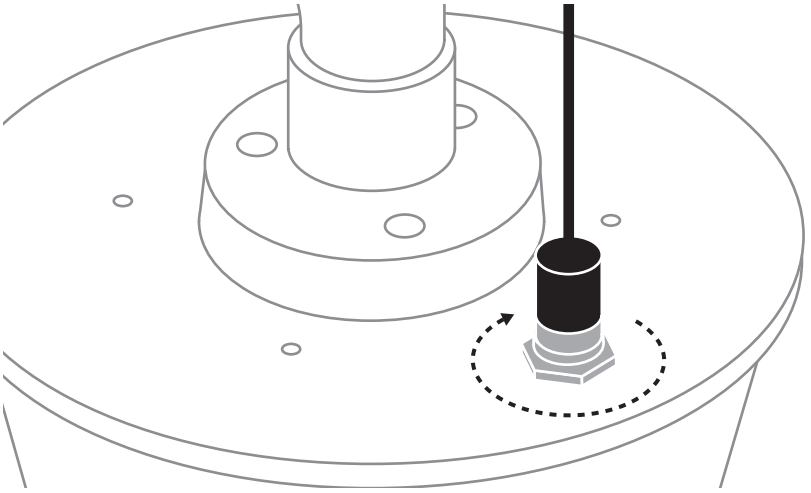

**Step 4** Plug other end of 110V cable into power outlet. Cable end will light up green when supplied with power.

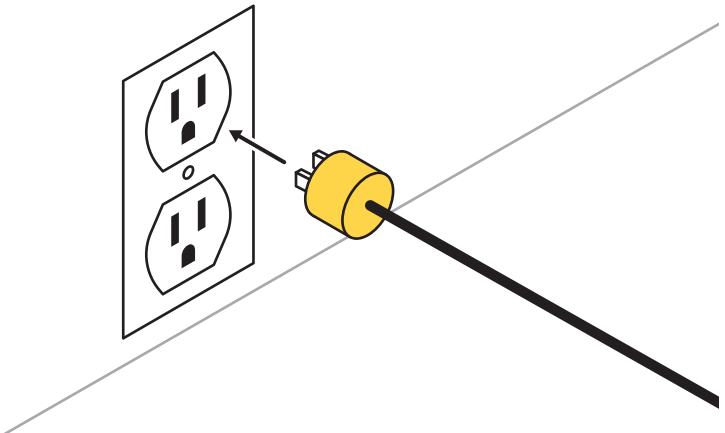

## Powering

**Step 5** Remove protective covering from camera. Your camera will be online and ready to use within 10 minutes.

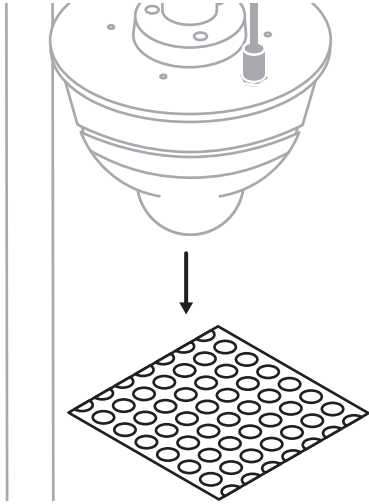

**Optional:** Secure power box on 110V cable to pole using zip ties (included) or to wall using appropriate hardware for your surface.

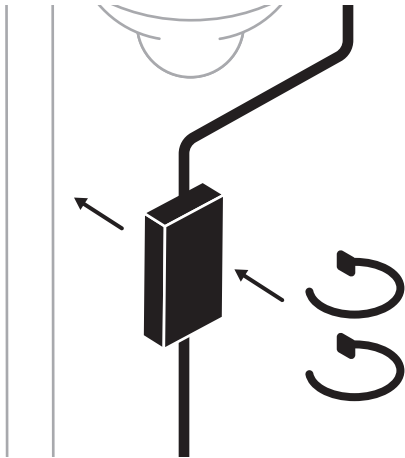

## Verifying Camera Operation

---

After providing your TrueLook Camera with power, wait **10 minutes** for it to come online. Then, use the link on the back of the manual to view the camera and verify its functionality.

If you don't see the camera in the TrueLook Platform, contact Customer Support for assistance.

## Maintenance Tips

---

- ✔ Camera is interior use only. Do not mount or store outdoors.
- ✔ Clean camera dome as needed using a microfiber cloth.
- ✔ Mounting hardware may loosen over time due to construction machinery causing vibrations. Regularly check that all hardware has remained tight.

# Troubleshooting

---

## Camera Not Operating Properly

1. Check that the power cable connector is securely fastened into input.
2. Check that the power source is supplying power. The power cable end will light up green when power is supplied.

If your system is still not functioning properly, please contact Customer Support for further assistance.



# Support Review

---

Once you're done with installation, snap a few pictures and email them to [support@truelook.com](mailto:support@truelook.com). If our Customer Support team notices anything they can help with, they'll reach out. This will also help with a quick review of your setup if you run into future issues.

## The Email

For the most efficient response from our team, include the following in your email:

1. Company name
2. Project name
3. Contact person for installation issues
4. The following photographs:
  - A. Your whole TrueLook solution: the camera, what it's mounted to, and any accessories
  - B. Close-ups of mounting
  - C. Close-ups of connections

# Notes

---

# Notes

---

# Accessing Your Camera

---

