

# Mobile Camera Trailer TrueDeter PTZ

---

## Installation Manual

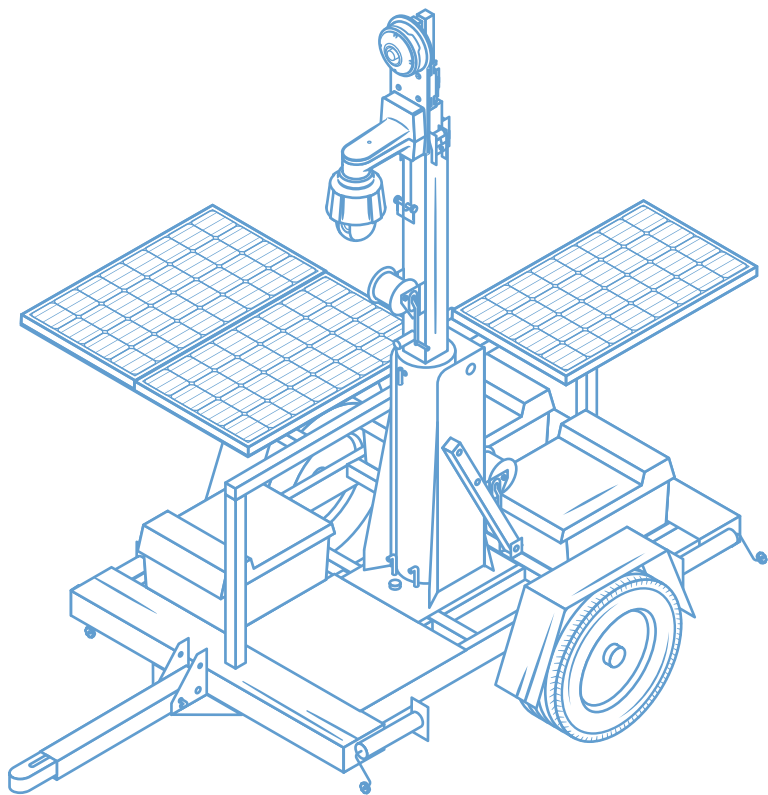

# Assembled Unit

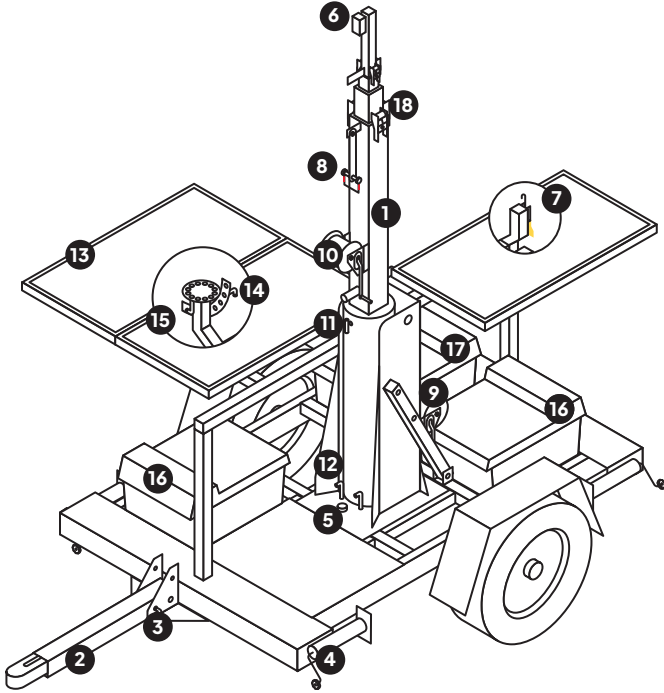

1. Mast
2. Trailer tongue
3. Trailer tongue pin
4. Jack stands (4)
5. Bubble level
6. Trailer power input
7. Yellow lock handle
8. Red lock pin
9. Mast raising winch
10. Mast extending winch
11. Mast rotation lock bolt
12. Mast locking pins
13. Solar panels
14. Panel angle adjuster bolt
15. Panel swivel lock bolt
16. Battery boxes (2)
17. Storage compartment
18. Mast stabilization rollers

# Unlimited Support

---

If you have any questions or issues with your TrueLook system, please don't hesitate to contact our Customer Support team.

**Phone** 833-878-3566 (Option 2)

**Email** [support@truelook.com](mailto:support@truelook.com)

You can also submit a support request online at:  
[support.truelook.com/contact-support](https://support.truelook.com/contact-support)

## Online Resources

---

Scan this QR code or visit [truelook.com/install](https://truelook.com/install) to access:

- ✔ A guide to administrative settings and time-lapse setup.
- ✔ Video demonstrations of installation procedures.
- ✔ Digital versions of all installation manuals.
- ✔ And more!



For Terms & Conditions, as well as Warranty information, visit:  
[truelook.com/terms-conditions](https://truelook.com/terms-conditions).

# Hardware Packing List

---

## Camera and Siren System [1x]

*Purchased models come pre-assembled.*

---

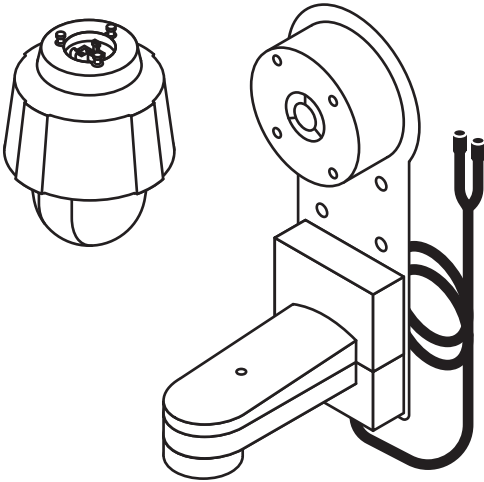

## Control Box [1x]

*Comes pre-mounted to mast adapter.*

---

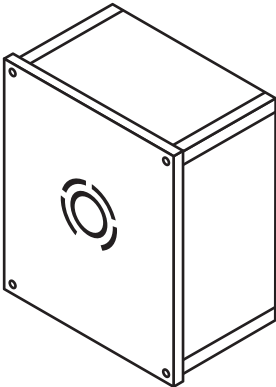

### Solar Load Cable [1x]

---



### Mast Mounting Hardware

---

#### Steel Straps [2x]

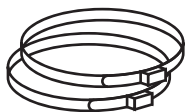

#### Mast Adapter [1x]

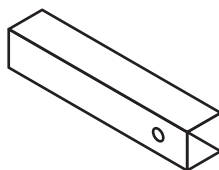

**Warning:** This equipment contains flashing lights, which may induce epileptic seizures in at-risk individuals.

# Trailer Positioning

---

**Place your camera trailer 20–150 feet away.**

For optimal viewing, place your trailer 20–150 feet away from the area of your jobsite that you wish to capture. The distance you choose will depend on the camera you've selected (PTZ or fixed-position), the size of your jobsite, and the amount of detail you want to see.

# Stabilizing the Trailer

---

**Step 1** Chock wheels on both sides of each wheel, then detach from your tow vehicle.

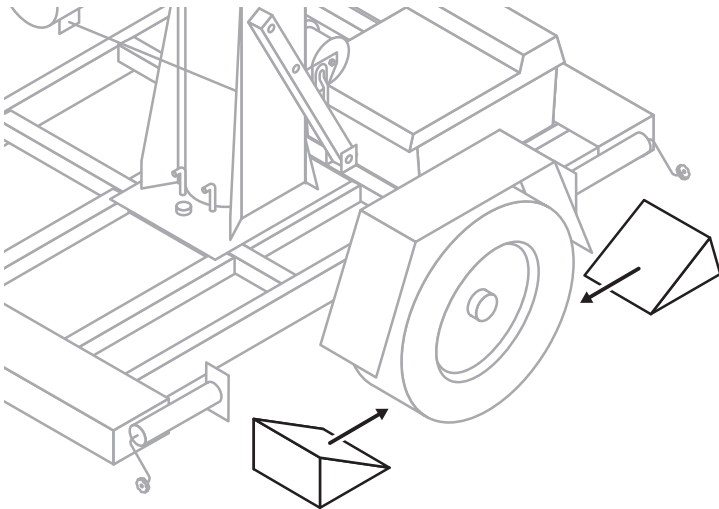

**Step 2** Lower and extend jack stands by pulling pin and turning jack stands vertical.

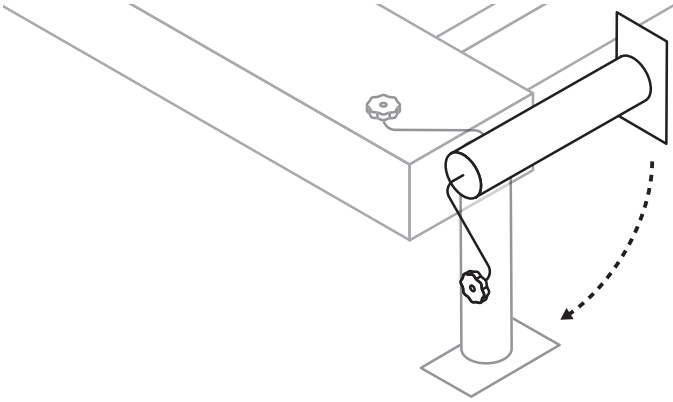

**Step 3** Check that trailer is level using built-in bubble level. Adjust jack stands as needed by turning handle clockwise to lower and counterclockwise to raise.

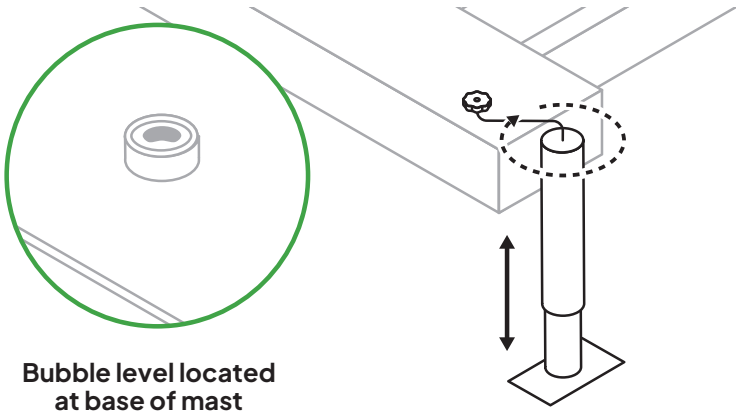

## Getting Started

**Step 4** To raise trailer tongue for storage, unhook clip and remove pin. Raise trailer tongue to stand upright, then place pin and hook clip to secure.

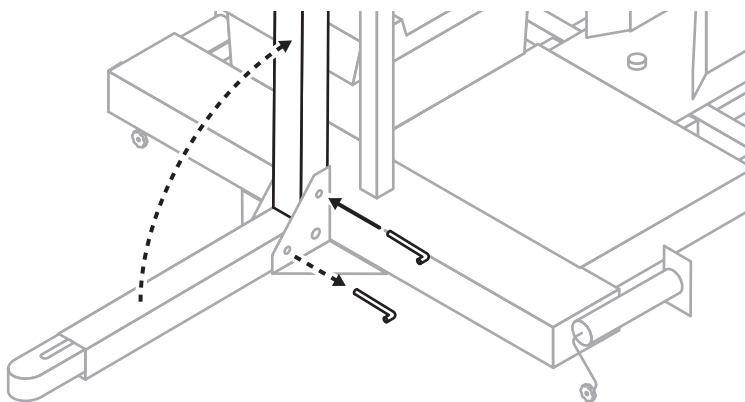



# Camera System

---

**Step 1** Flip mast adapter with control box attached so control box is facing down.

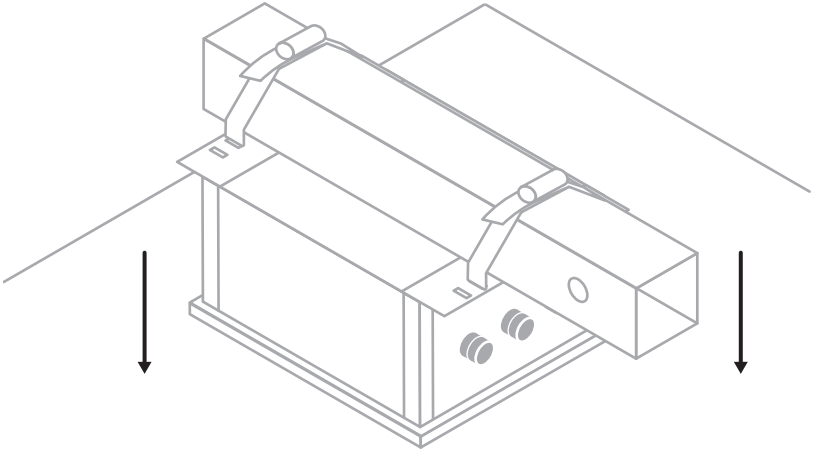

**Step 2** Thread steel straps through top and bottom of pole mount on back of plate.

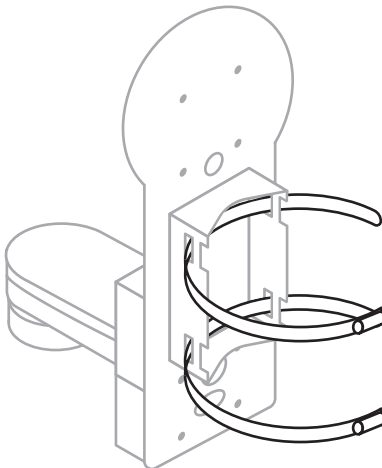

## Camera Installation

**Step 3** Tighten each strap around mast adapter using drill with 5/16 hex head driver bit (not included).

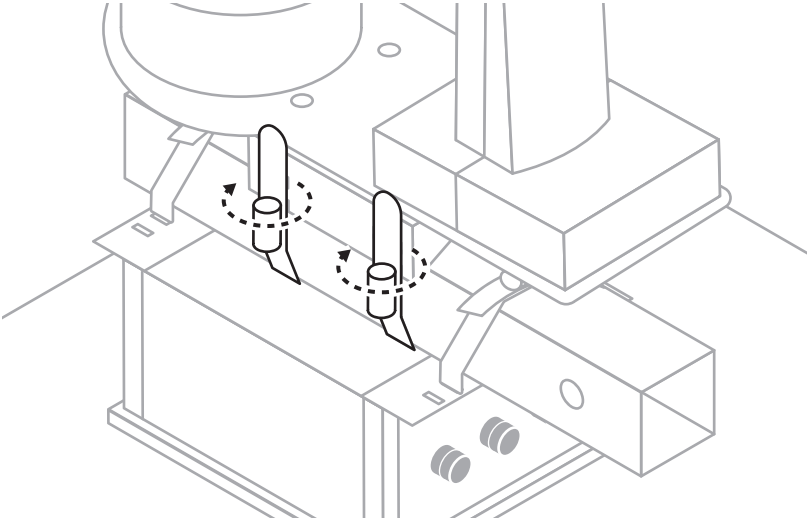

**Step 4** Trim steel straps to desired length using tin snips (not included).

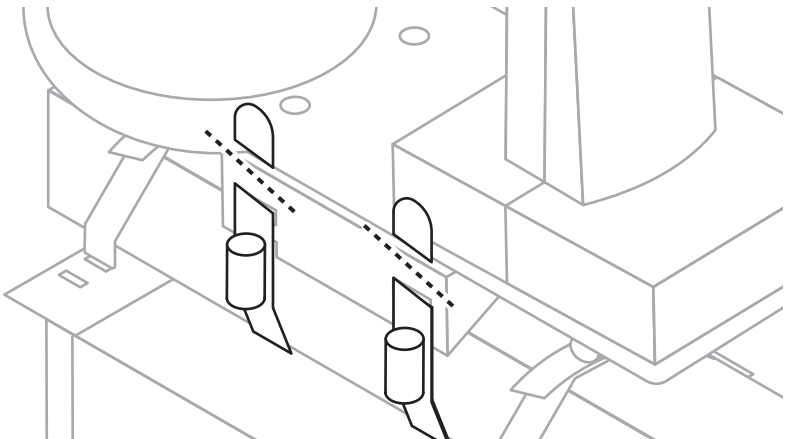

**Step 5** Slide mast adapter with camera system and control box installed onto trailer mast end.

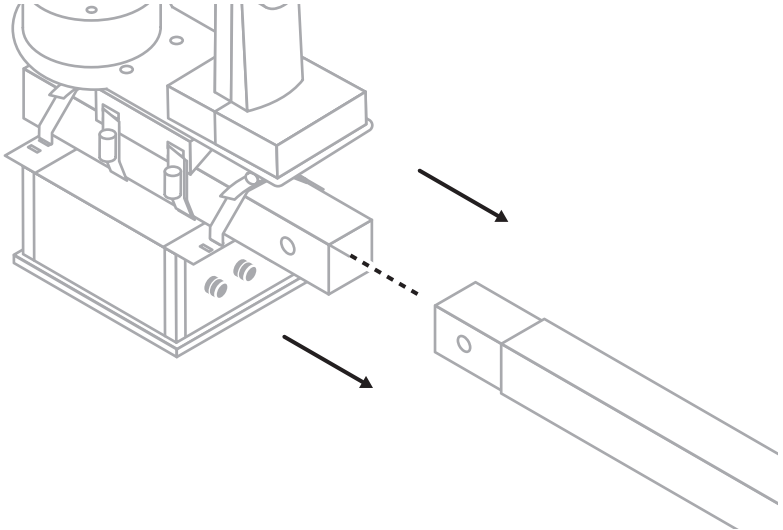

**Step 6** Secure mast adapter to mast with two bolts using a 19mm socket wrench (not included).

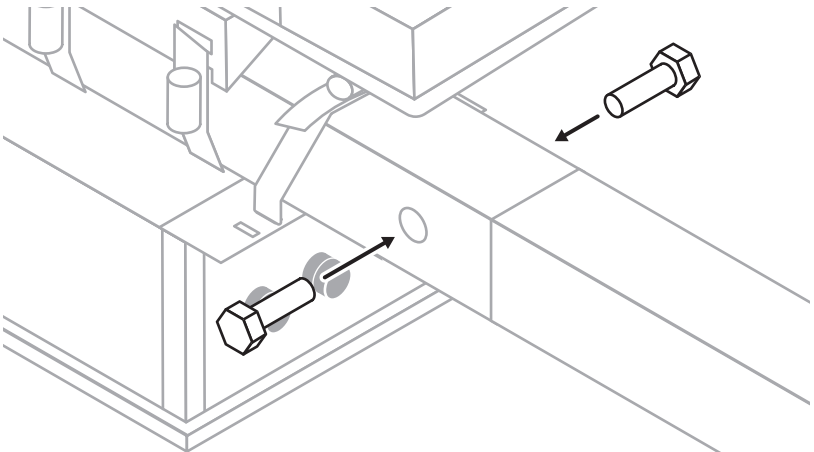

## Camera Installation

**Step 7** Remove pendant mount top by using T30 Torx screwdriver (not included) to loosen screw.

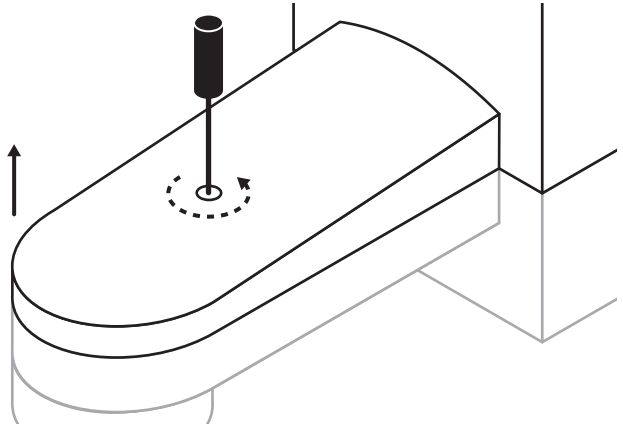

**Step 8** Push camera up into pendant housing and rotate a quarter turn until it snaps into place, aligning with screw holes.

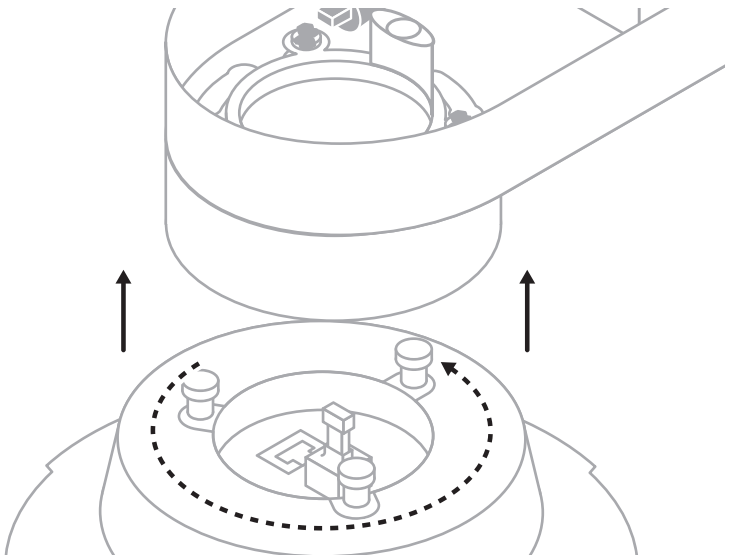

**Step 9** Secure camera to pendant housing by tightening screws using T30 Torx screwdriver.

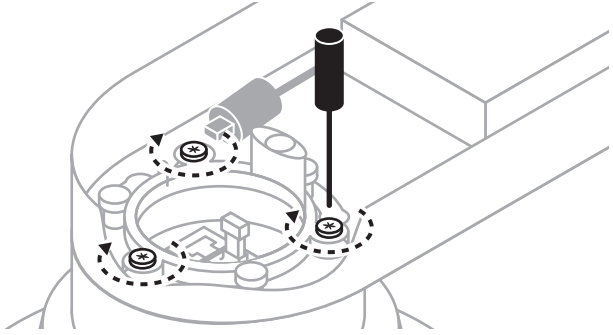

**Step 10** Plug connector coming from camera mount into top of camera. Connector should snap firmly into place.

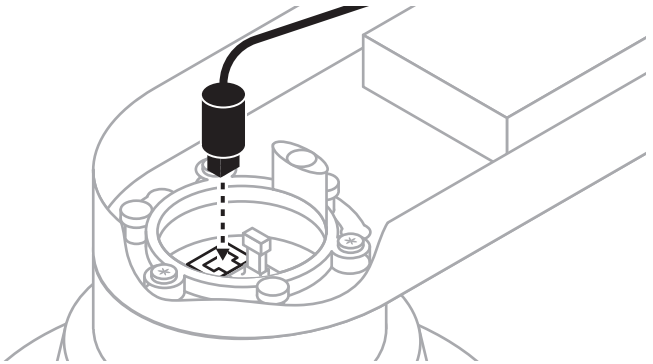

**Warning:** Removal of black fiber port cap can lead to water damage. Replace cap if it has been removed. It should snap firmly in place.

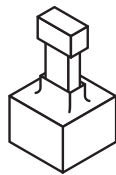

## Camera Installation

**Step 11** Secure pendant mount top by placing it back on and tightening screw.

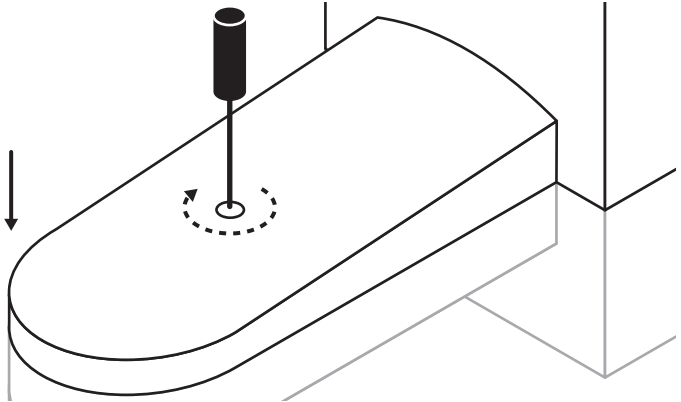

## Connecting

**Step 1** Twist protective plug caps off bottom of control box. The caps should hang freely.

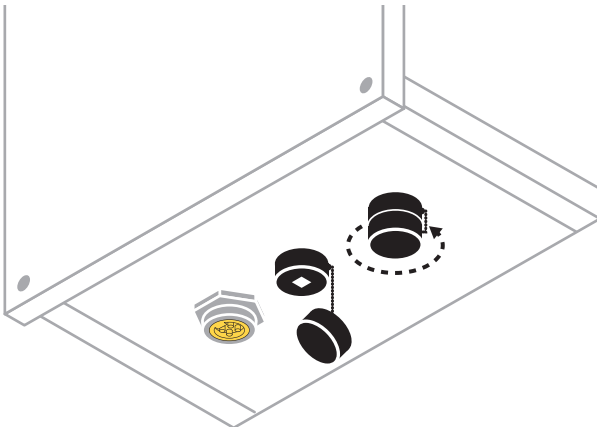

**Step 2** Connect camera system to control box by plugging in both connectors of braided cable coming from camera. Connectors go into either socket and should snap firmly in place.

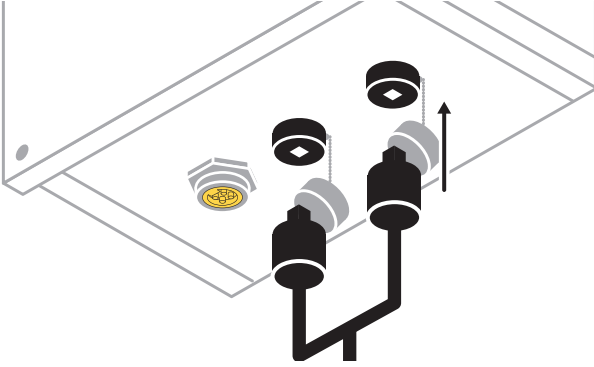

**Step 3** Twist protective plug caps on connectors up into bottom of control box. This will create a watertight seal.

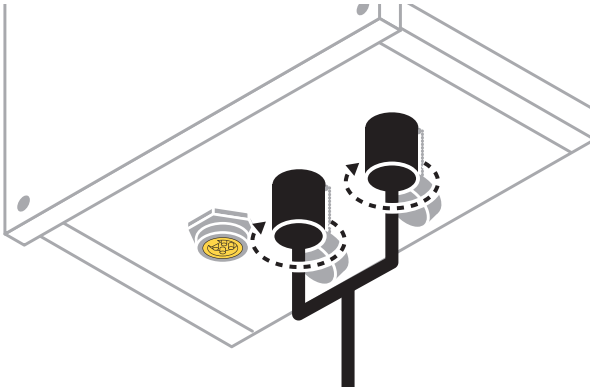

**Warning:** Do not use tools to tighten cap. Cap should be snug, but will not be flush against the enclosure.

## Camera Installation

**Step 4** Provide power by aligning notches and plugging one end of solar load connector into control box power input. Gently hand tighten to screw silver collar into input.

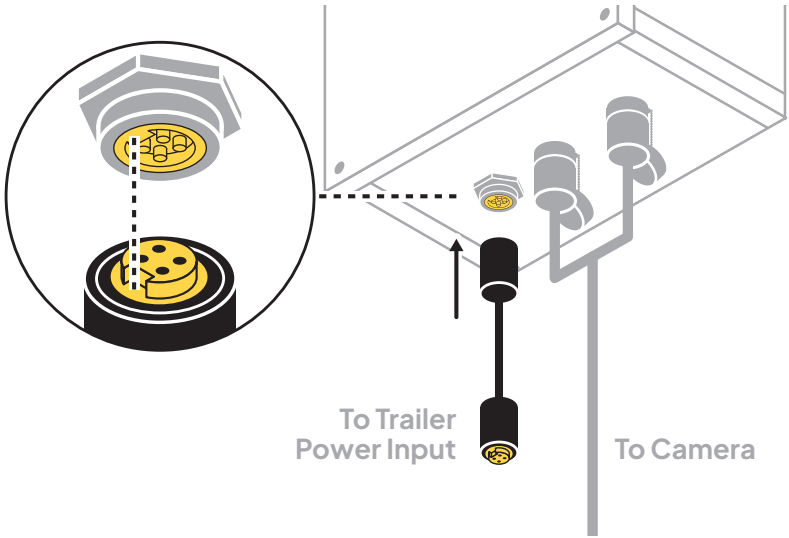

**Step 5** Repeat step 4 to connect other end of solar load connector into trailer power input located on mast.

**Warning:** Never use tools to tighten connectors. This may result in over tightening and could break connector.

**Step 6** Remove protective covering from camera.



## Raising the Mast

**Warning:** Check for overhead obstructions before raising mast. Do not stand beneath mast when raising or lowering.

**Step 1** Release yellow lock handle by pulling handle toward yourself.

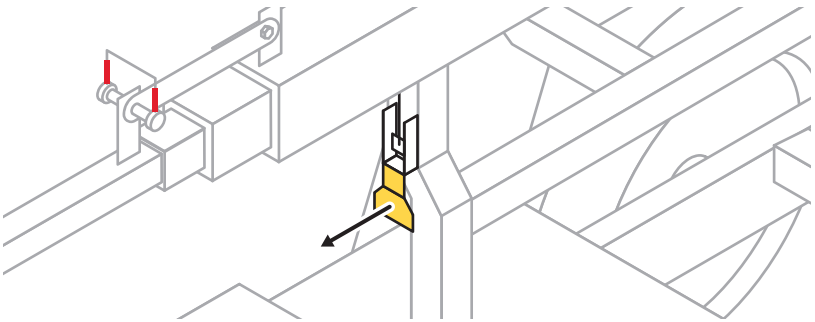

**Step 2** Release red lock pin by unhooking wire and removing pin. Hook wire back onto red lock pin to avoid entanglement while raising mast.

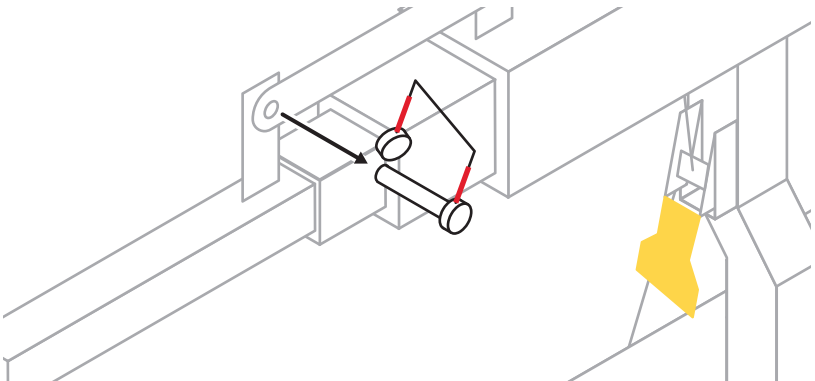

## Trailer Setup

**Step 3** Raise mast into vertical position using lower winch.

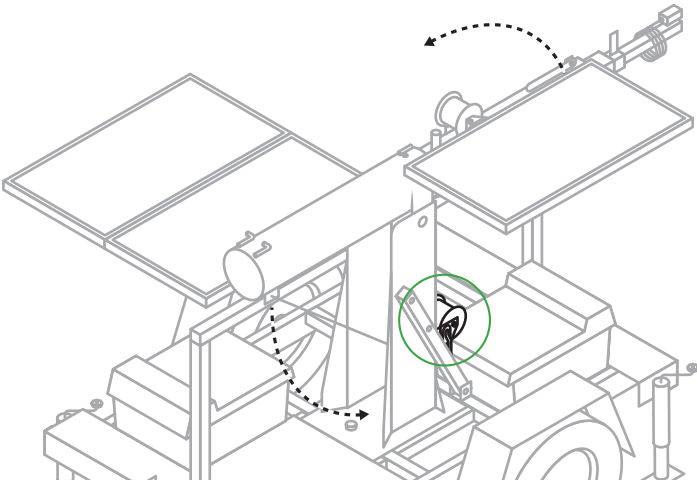

**Step 4** Secure mast by pushing two locking pins into holes on base of mast. Mast must be fully upright for pin holes to align.

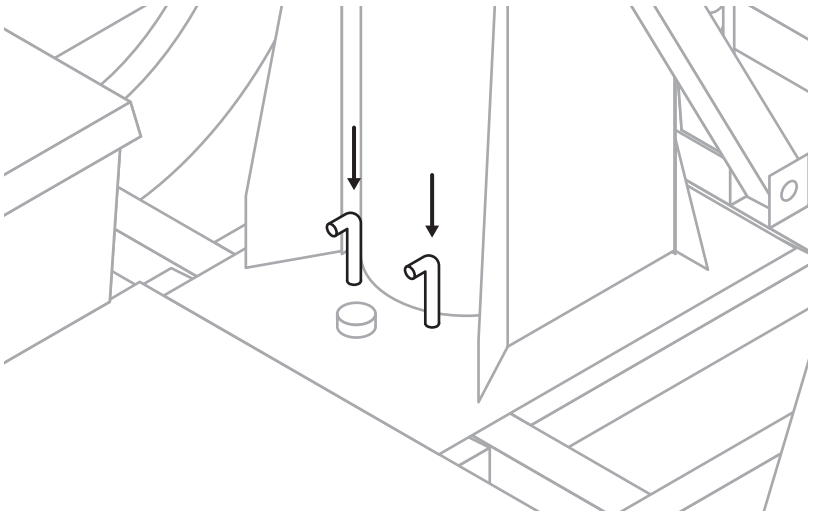

**Step 5** Raise mast until desired height is reached using higher winch. Maximum mast height is 30 feet.

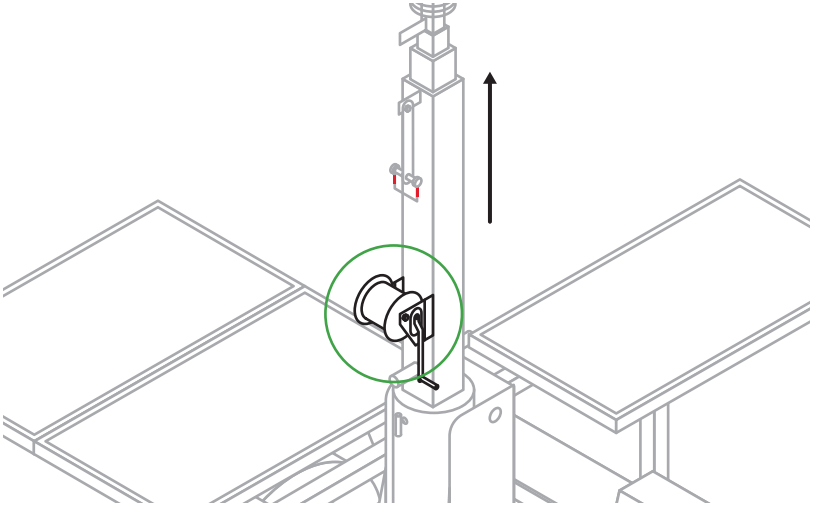

**Step 6** Fully loosen rotation lock bolt and rotate mast to desired position. Once position is achieved, re-tighten locking bolt.

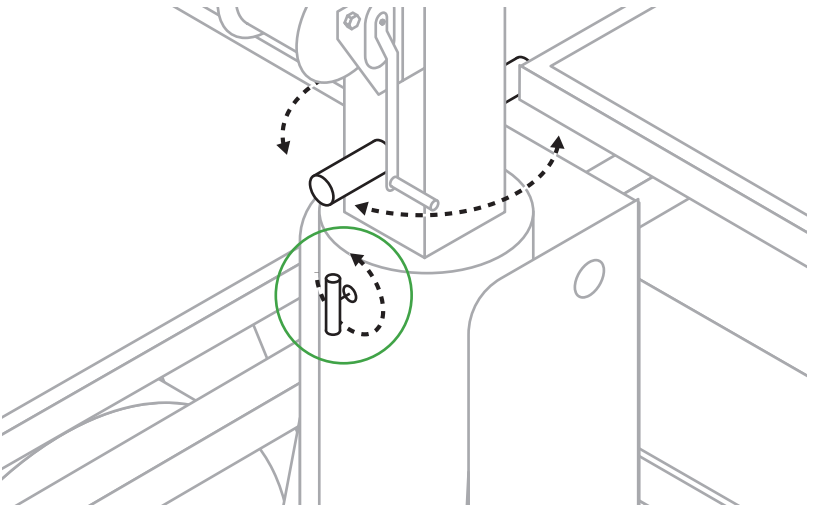

# Solar Panel Positioning

**Warning:** Solar panels must face the equator (directly south) in order to capture adequate sunlight and properly charge. Failure to observe all following requirements may result in system downtime. Units self-recover automatically once panels receive sufficient sunlight.

**Step 1** Remove pin(s) from travel arm(s) to unlock solar panels.

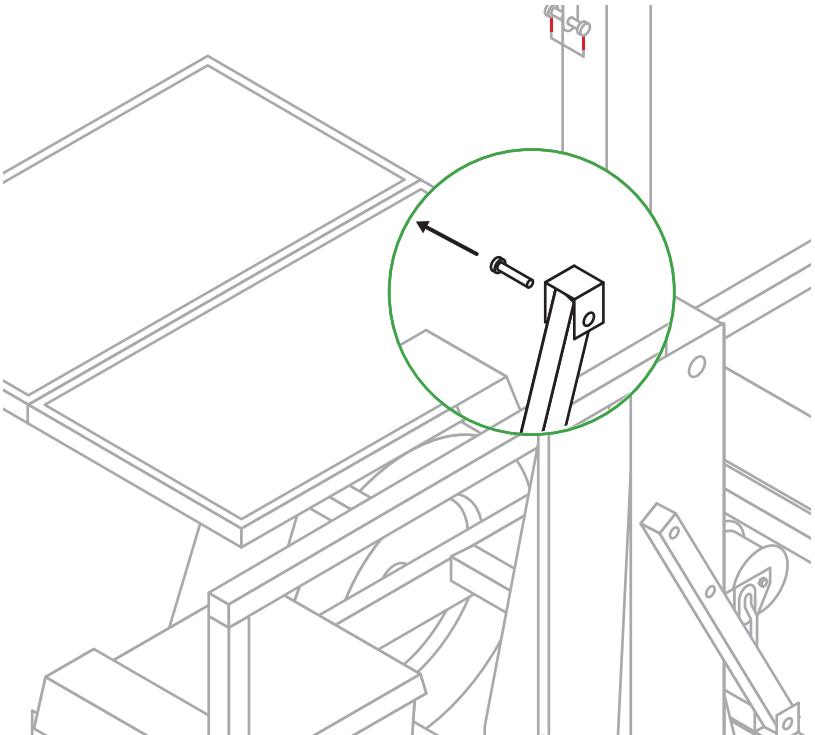

**Step 2** Face panels due south by pulling down on panel swivel lock bolt and turning panels. Replace lock bolt to secure.

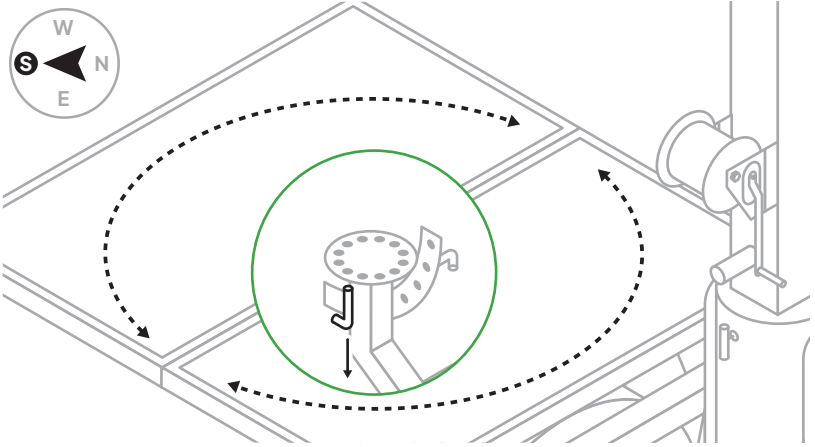

**Step 3** Angle solar panels for your location by removing panel angle adjuster bolt and placing it in corresponding hole. Refer to the chart on the following page to determine the proper angle based on your location.

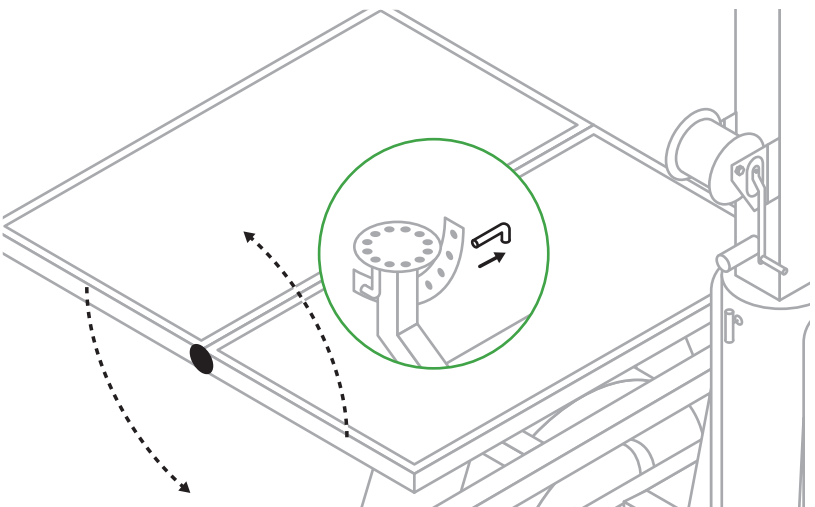

## Trailer Setup

Alabama	45°	Montana	70°
Alaska	80°	Nebraska	65°
Arizona	45°	Nevada	65°
Arkansas	60°	New Hampshire	65°
California	45°	New Jersey	65°
Colorado	55°	New Mexico	45°
Connecticut	60°	New York	65°
Delaware	65°	North Carolina	60°
District of Col.	60°	North Dakota	70°
Florida	45°	Ohio	60°
Georgia	55°	Oklahoma	50°
Hawaii	40°	Oregon	65°
Idaho	65°	Pennsylvania	65°
Illinois	65°	Rhode Island	65°
Indiana	65°	South Carolina	55°
Iowa	65°	South Dakota	65°
Kansas	65°	Tennessee	60°
Kentucky	60°	Texas	45°
Louisiana	45°	Utah	65°
Maine	65°	Vermont	65°
Maryland	60°	Virginia	60°
Massachusetts	65°	Washington	65°
Michigan	65°	West Virginia	60°
Minnesota	65°	Wisconsin	65°
Mississippi	45°	Wyoming	65°
Missouri	60°		

**Step 4** Ensure panels remain unobstructed. Panels must receive direct sunlight throughout the day. Do not let trees, equipment, structures, or anything else block the sun.

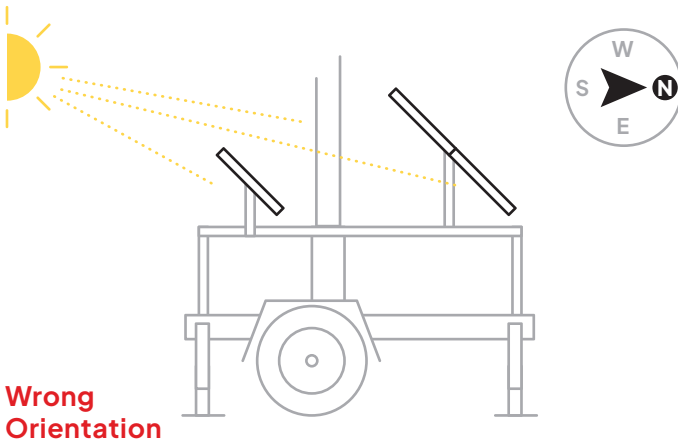
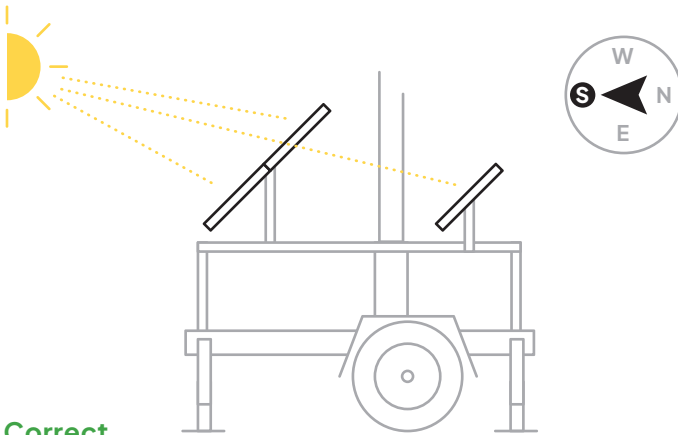

# Powering

---

**Step 1** Open battery compartment and locate three breaker switches. Flip all three switches up into ON position.

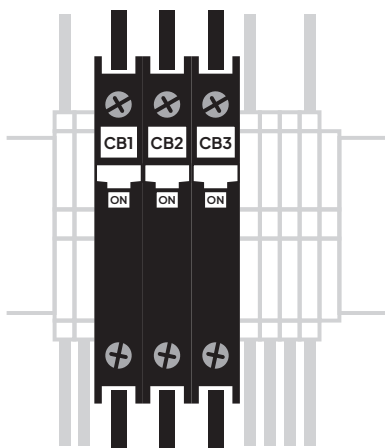

**Step 2** Verify the panels are charging the unit. With sunlight, the leftmost LED on the ProStar unit will turn green within 5 minutes after powering.

- A yellow LED lit on the ProStar unit means your panels are not receiving sunlight, and the camera is running on battery power.
- A red LED lit on the ProStar unit means there is an issue with your system. Please contact TrueLook Support.



**Step 3** Verify that the following numbers are displayed on the ProStar's digital readout. You may need to cycle left/right using the arrows to get to the pictured screen.

If numbers are displayed correctly, the system should be fully functioning at this stage.

**Solar Amps** ☀️  
0.5 - 4+

**Battery** 🔋  
12 - 14+

**Load Amps** ⚡️  
0.3 - 0.7

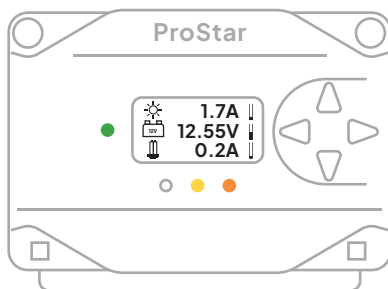

**Step 4** Verify that there are two green LED lights on the EMC-1 unit.

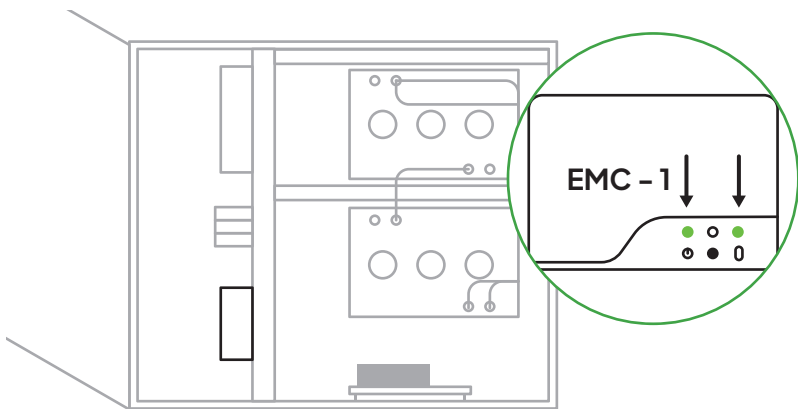

# Trailer Setup

**Step 5** Verify that there are two green LEDs and one amber LED lit on the modem mounted to the side of the battery compartment.

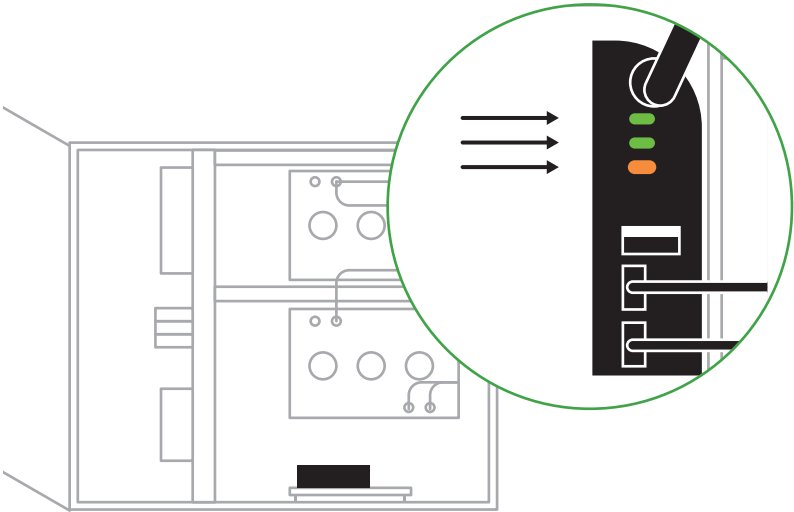

## Verifying Camera Operation

---

After providing your TrueLook Camera with power, wait **10 minutes** for it to come online. Then, use the link on the back of the manual to view the camera and verify its functionality.

If you don't see the camera in the TrueLook Platform, contact Customer Support for assistance.

## Maintenance Tips

---

- ✔ Do not allow smoking or open flames near battery compartment.
- ✔ Do not disassemble the ProStar from its case. There are no user serviceable parts inside the ProStar.
- ✔ Regularly check that tire pressure is 45 psi (310 kPa).
- ✔ Clean camera as needed using a microfiber cloth.
- ✔ The solar panels are designed to quickly melt snow on their own. If there is a more urgent need to remove snow, gently use a soft brush. Using too much force may scratch or damage the panels.
- ✔ Mounting hardware may loosen over time due to construction machinery causing vibrations. Be sure to regularly check that all hardware has remained tight.

# Troubleshooting

---

If something seems wrong with the system, it may be necessary to troubleshoot.

### **Cautions:**

- Troubleshooting should be attempted by qualified personnel only.
- A battery can cause serious damage if shorted.
- Do not disassemble the ProStar from its case. There are no user serviceable parts inside the ProStar.

## Camera Not Operating Properly

1. Check that the load breaker is turned on.
2. Check that the camera cable connectors are securely fastened.
3. If the ProStar internal temperature is above 80°C/176°F, the load will be disconnected, and all LEDs will be flashing in sequence.

## Battery Is Not Charging

1. Check that all wire connections in the system are correct and tight.

If your system is still not functioning properly, please contact TrueLook Support for further assistance.

## Mast Stabilization

Due to a variety of factors (local weather conditions, camera weight, etc.), you may notice the trailer mast swaying. If you experience this, please follow these steps to increase your mast's stability.

**Step 1** Lower the mast and locate the six rollers on the trailer. There are two sets of three; one set in the middle section of the extendable mast and one set near the top of the extendable mast.

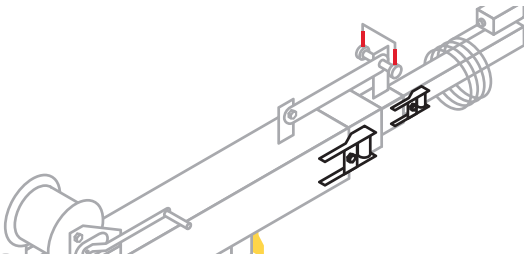

**Step 2** Tighten each roller using a T25 Allen wrench (not included) by inserting the wrench into the keyhole below each roller and turning clockwise one revolution.

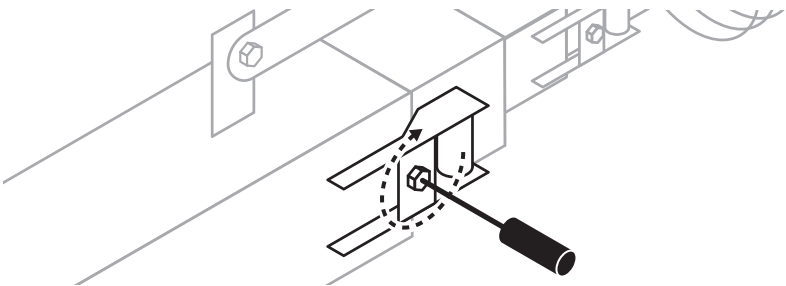

**Step 3** Repeat with all remaining keyholes.

# Support Review

---

Once you're done with installation, snap a few pictures and email them to [support@truelook.com](mailto:support@truelook.com). If our Customer Support team notices anything they can help with, they'll reach out. This will also help with a quick review of your setup if you run into future issues.

## The Email

For the most efficient response from our team, include the following in your email:

1. Company name
2. Project name
3. Contact person for installation issues
4. The following photographs:
  - A. Your whole TrueLook solution: the camera, what it's mounted to, and any accessories
  - B. Close-ups of mounting
  - C. Close-ups of connections

## Notes

---

# Accessing Your Camera

---

