

TrueDeter Fixed

Installation Manual

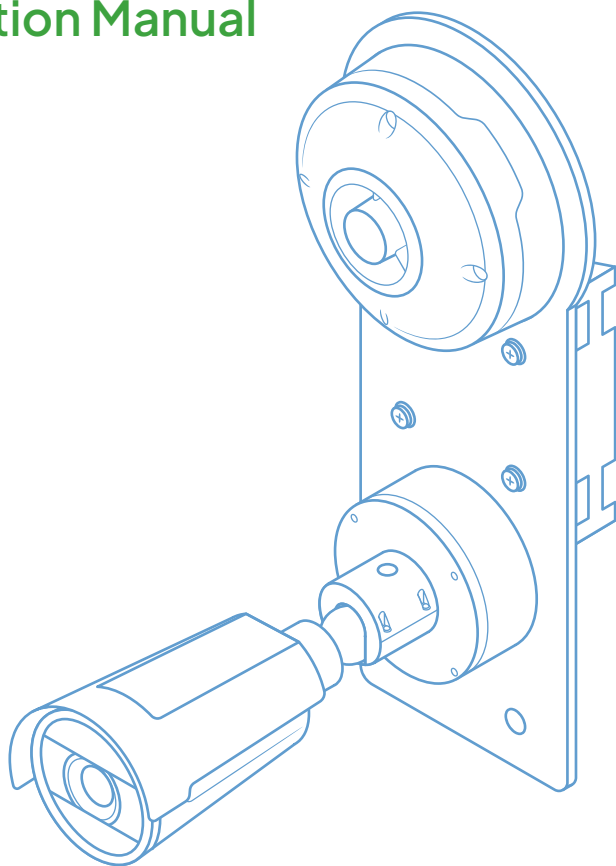

Assembled Unit

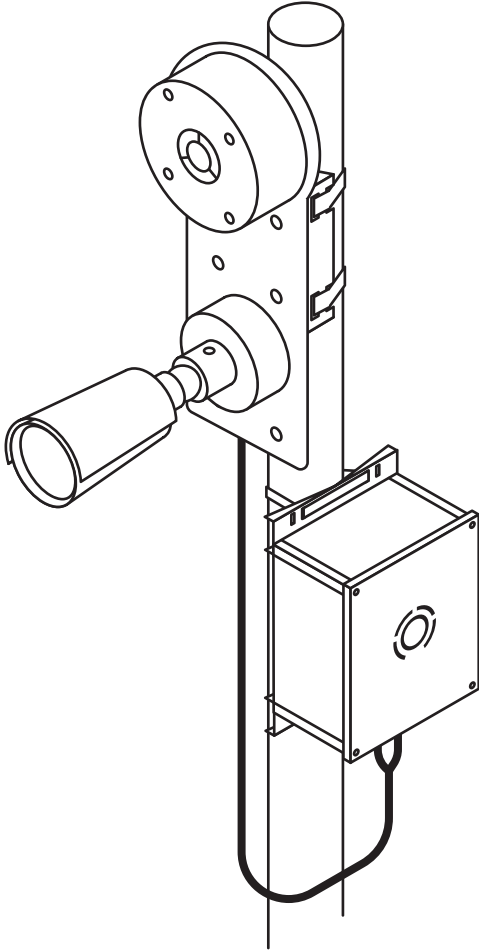

Unlimited Support

If you have any questions or issues with your TrueLook system, please don't hesitate to contact our Customer Support team.

Phone 833-878-3566 (Option 2)

Email support@truelook.com

You can also submit a support request online at:

support.truelook.com/contact-support

Online Resources

Scan this QR code or visit truelook.com/install to access:

- ✔ A guide to administrative settings and time-lapse setup.
- ✔ Video demonstrations of installation procedures.
- ✔ Digital versions of all installation manuals.
- ✔ And more!



For Terms & Conditions, as well as Warranty information, visit: truelook.com/terms-conditions.

Hardware Packing List

Camera System [1x]

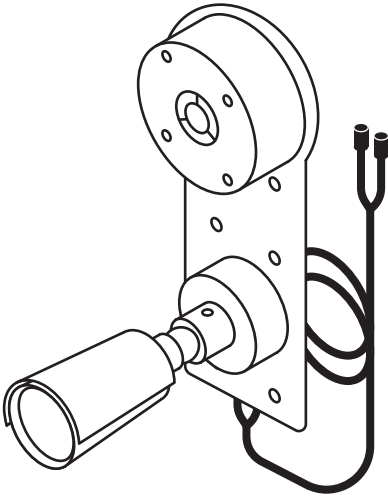

Control Box [1x]

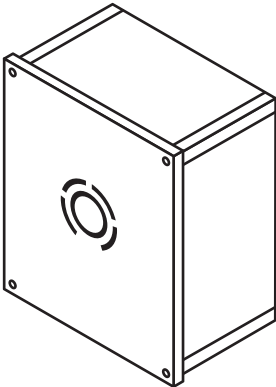

Pole Mounting Hardware

Steel Straps [4x]

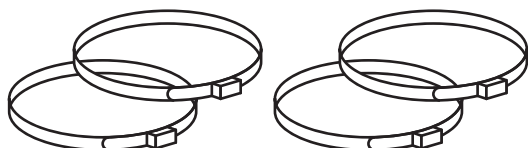

Wall Mounting Hardware

L Brackets [4x]

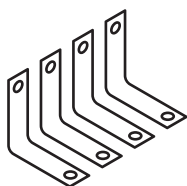

Mounting Feet [4x]

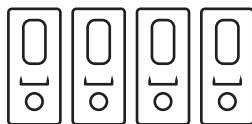

Screws [4x]



Flat Washers [4x]



Lock Washers [4x]



Nuts [4x]



Assorted Hardware

Allen Wrench [1x]

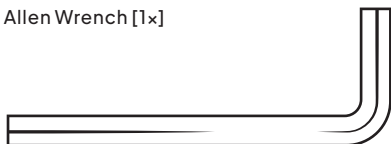

Warning: This equipment contains flashing lights, which may induce epileptic seizures in at-risk individuals.

Pole Mounting

Camera System

Step 1 Thread steel straps through top and bottom of pole mount on back of plate.

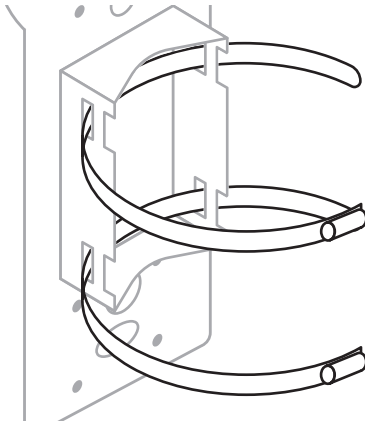

Step 2 Tighten each strap around pole using drill with 5/16 hex head driver bit (not included).

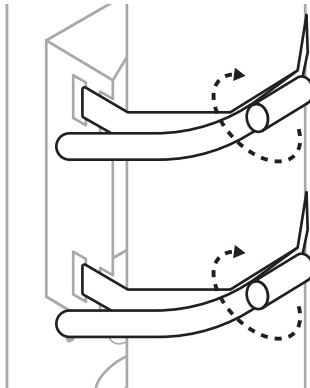

Step 3 Trim steel straps to desired length using tin snips (not included).

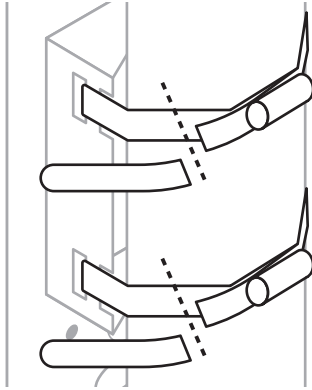

Step 4 Loosen screw on camera neck with Allen wrench (included) to adjust camera angle. Tighten screw on camera neck with Allen wrench when desired angle is chosen.

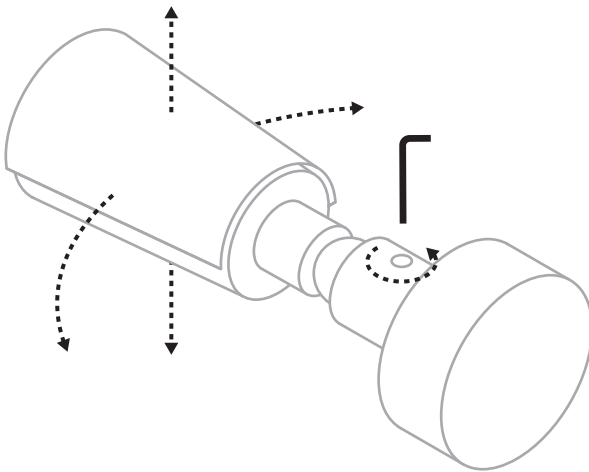

Control Box

Step 1 Thread steel straps through pole mounting hardware on top and bottom of control box.

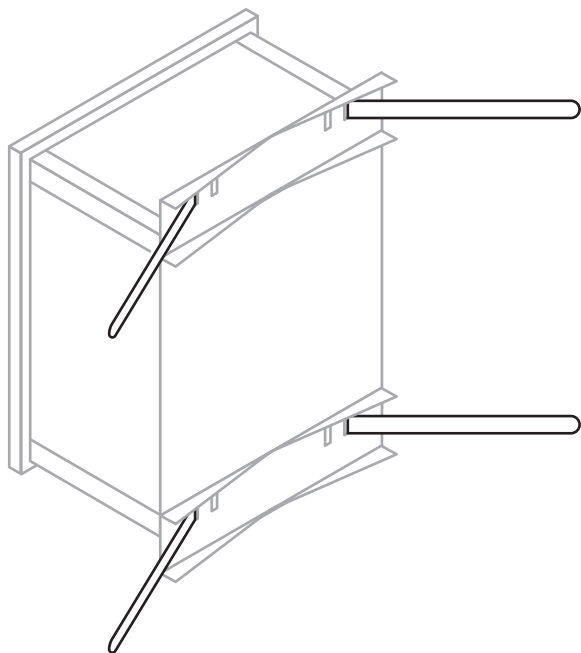

For large diameter poles

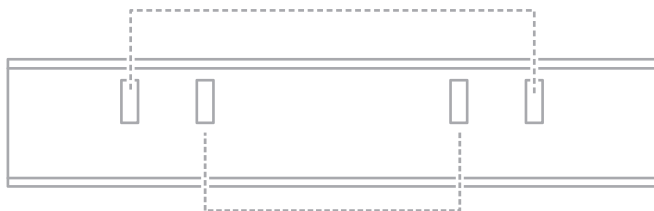

For small diameter poles

Step 2 Tighten each strap around pole using drill with 5/16 hex head driver bit.

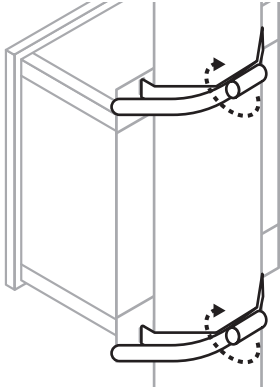

Step 3 Trim steel straps to desired length using tin snips.

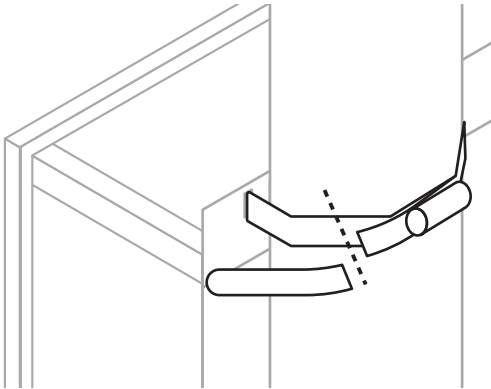

Wall Mounting

Camera System

Step 1 Attach wall mounting hardware to sides of pole mount with screw, washer, lock washer, and nut, using drill with Phillips #2 bit (not included) on screws and pliers (not included) to hold nuts tight.

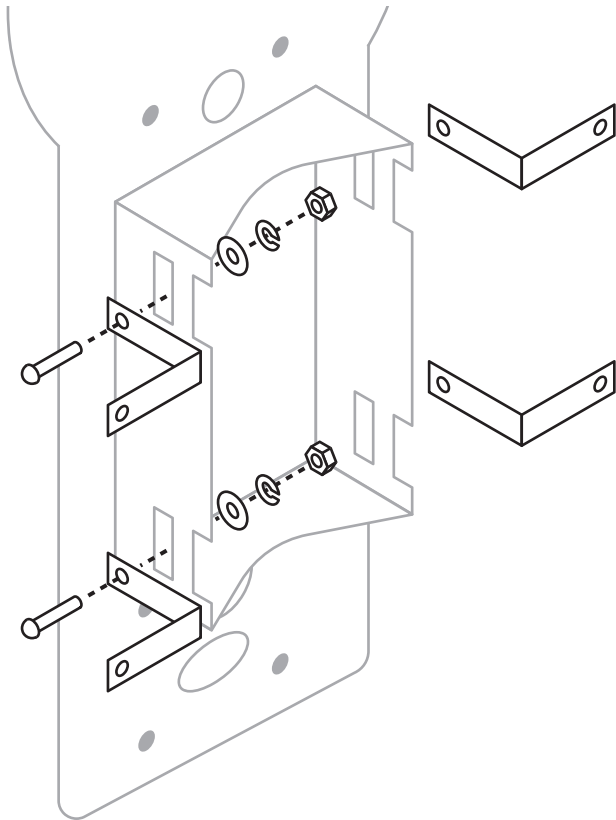

Step 2 Using hardware appropriate for your mounting surface, attach camera to wall.

Step 3 Loosen screw on camera neck with Allen wrench (included) to adjust camera angle. Tighten screw on camera neck with Allen wrench when desired angle is chosen.

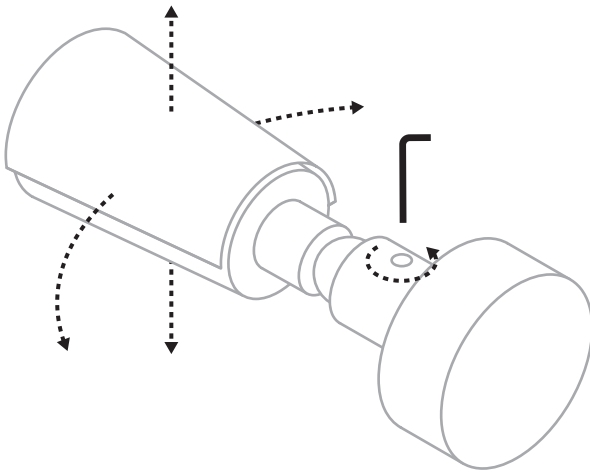

Control Box

Step 1 Remove pole mounting hardware from back of control box using drill with Phillips #2 bit.

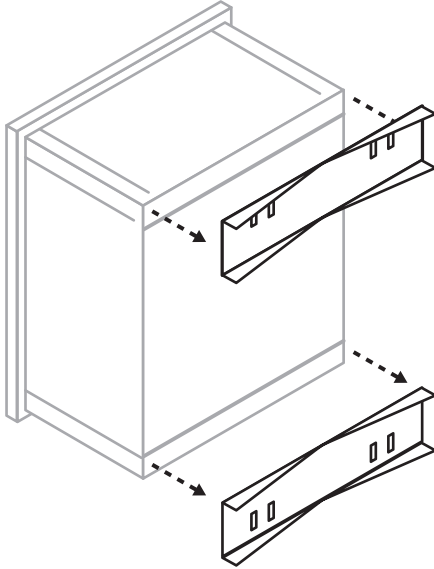

Step 2 Attach mounting feet to back of control box using same screws and drill with Phillips #2 bit.

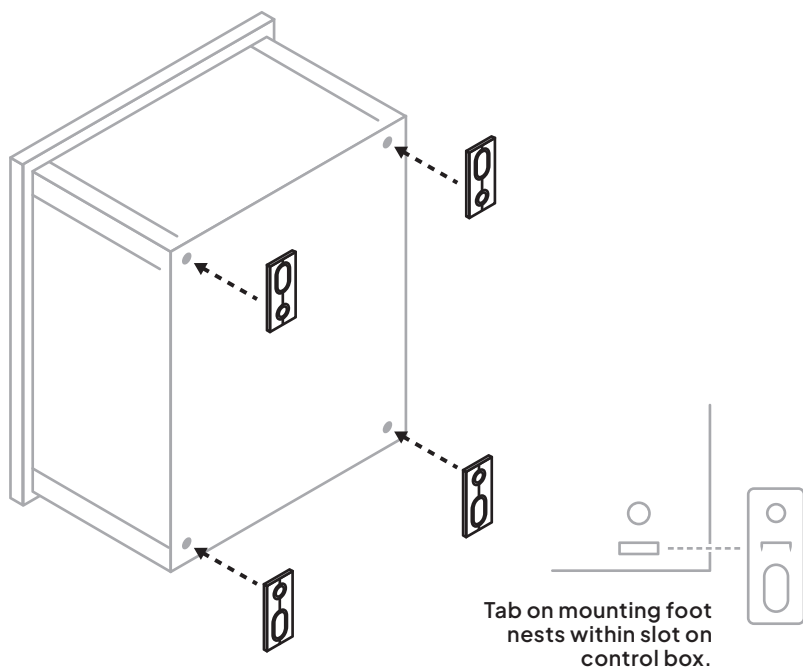

Step 3 Using hardware appropriate for your mounting surface, attach control box to wall.

Connecting & Powering

Step 1 Twist protective plug caps off bottom of control box. The caps should hang freely.

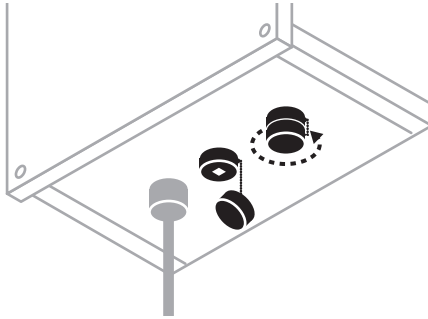

Step 2 Connect camera system to control box by plugging in both connectors of braided cable coming from camera. Connectors go into either socket and should snap firmly in place.

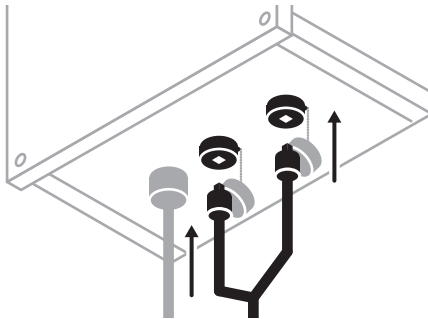

Step 3 Twist protective plug caps on connectors up into bottom of control box. This will create a watertight seal.

Warning: Do not use tools to tighten cap. Cap should be snug, but will not be flush against the enclosure.

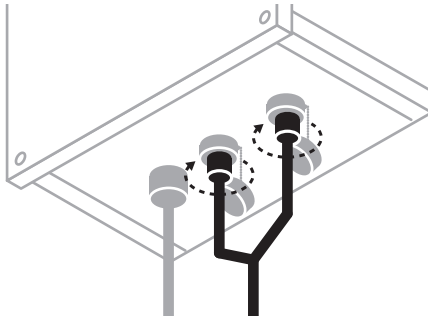

Step 4 Connect control box to power.

For solar-powered cameras: At this point, please proceed to the manual for your solar system for setup and powering instructions.

Step 5 Remove protective covering from camera lens.

Verifying Camera Operation

After providing your TrueLook Camera with power, wait **10 minutes** for it to come online. Then, use the link on the back of the manual to view the camera and verify its functionality.

If you don't see the camera in the TrueLook Platform, contact Customer Support for assistance.

Maintenance Tips

- ✔ Clean camera lens as needed using a microfiber cloth.
- ✔ Mounting hardware may loosen over time due to construction machinery causing vibrations. Be sure to regularly check that all hardware has remained tight.

Troubleshooting

If something seems wrong with the system, it may be necessary to troubleshoot.

Camera Not Operating Properly

1. Check that the camera cable connectors are securely fastened into the control box.
2. Check that the power source is supplying power.

If your system is still not functioning properly, please contact Customer Support for further assistance.

Support Review

Once you're done with installation, snap a few pictures and email them to support@truelook.com. If our Customer Support team notices anything they can help with, they'll reach out. This will also help with a quick review of your setup if you run into future issues.

The Email

For the most efficient response from our team, include the following in your email:

1. Company name
2. Project name
3. Contact person for installation issues
4. The following photographs:
 - A. Your whole TrueLook solution: the camera, what it's mounted to, and any accessories
 - B. Close-ups of mounting
 - C. Close-ups of connections

Notes

Accessing Your Camera

