

Fixed & PTZ Cameras

Installation Manual

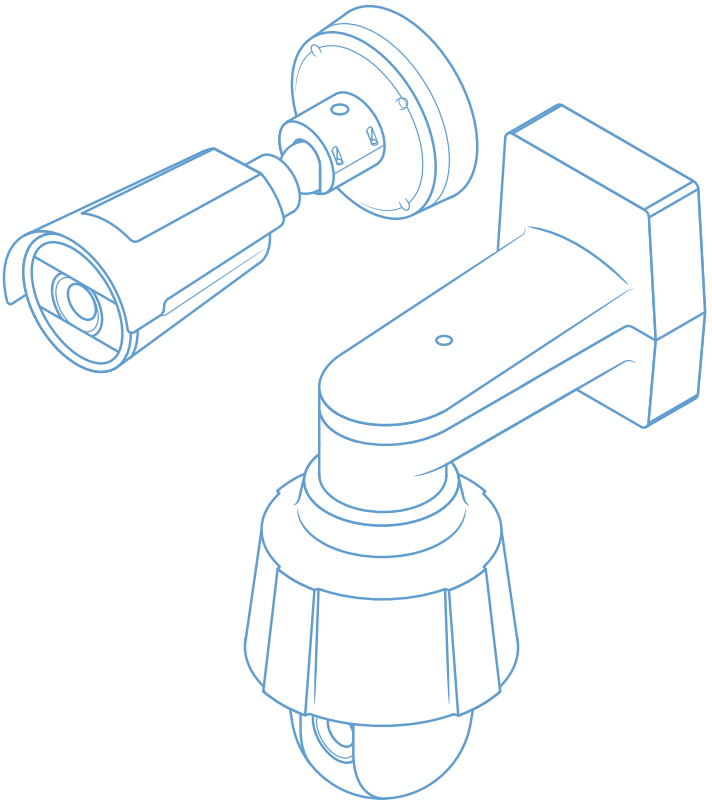

Unlimited Support

If you have any questions or issues with your TrueLook system, please don't hesitate to contact our Customer Support team.

Phone 833-878-3566 (Option 2)

Email support@truelook.com

You can also submit a support request online at:

support.truelook.com/contact-support

Online Resources

Visit truelook.com/install to access:

- ✔ A guide to administrative settings and time-lapse setup
- ✔ Video demonstrations of installation procedures
- ✔ And more!

For Terms & Conditions, as well as Warranty information, visit: truelook.com/terms-conditions.

Hardware Packing List

Camera [1x]

Fixed

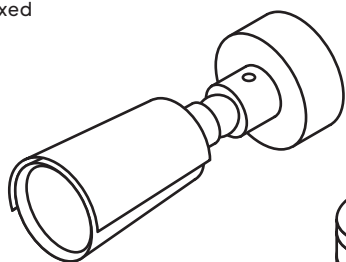

PTZ

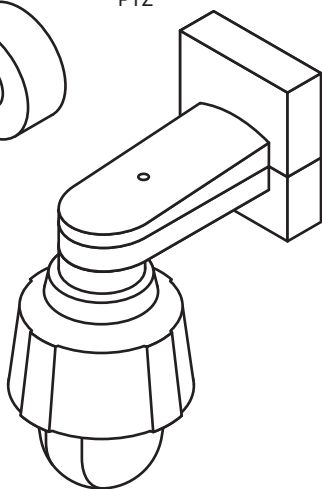

Control Box [1x]

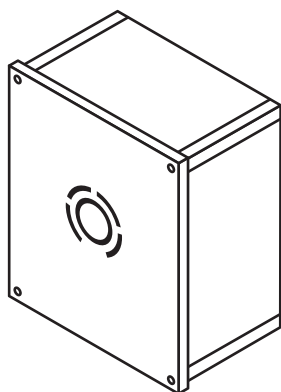

Getting Started

Power Cord [1x]

Type of cord depends on order.

20' 110V Power Cord

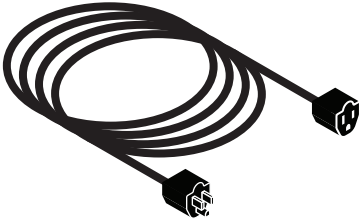

20' Solar Power Cord



Pole Mounting Hardware

Steel Straps [4x]

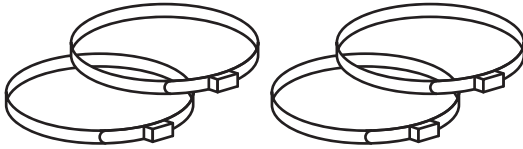

Assorted Hardware

Only provided with fixed cameras.

T-25 Allen Wrench [1x]

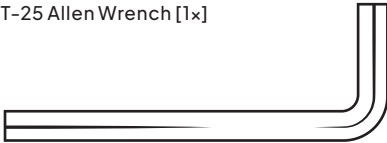

Preparing for Installation

Warning: Some cameras weigh up to 16 pounds. At least two people are recommended for safe installation.

Determine Mounting Hardware

Wall Mounting

Your mounting kit **does not include** hardware for wall mounting. Choose appropriate mounting hardware for your surface.

Pole Mounting

Notice: Exact camera model may not be shown. All cameras mount using same steps.

Camera

Step 1 Thread steel straps through top and bottom of pole mount.

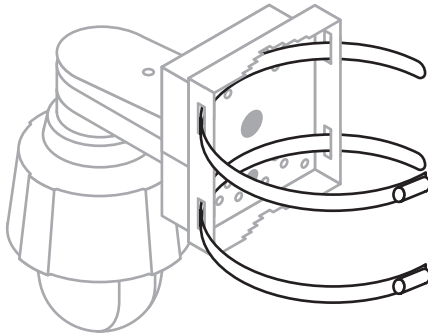

Step 2 Tighten each strap around pole using drill with 5/16 hex head driver bit (not included).

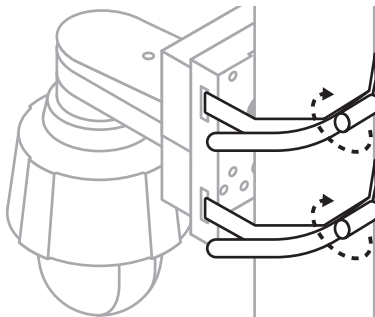

Installation

Step 3 Trim steel straps to desired length using tin snips (not included).

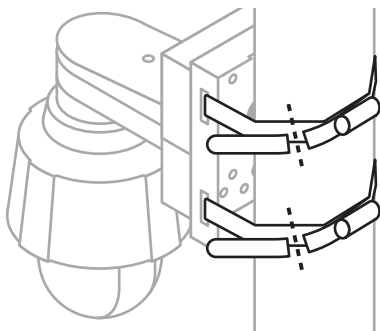

Step 4 Remove protective covering from camera.

Control Box

Step 1 Thread steel straps through pole mounting hardware on top and bottom of control box.

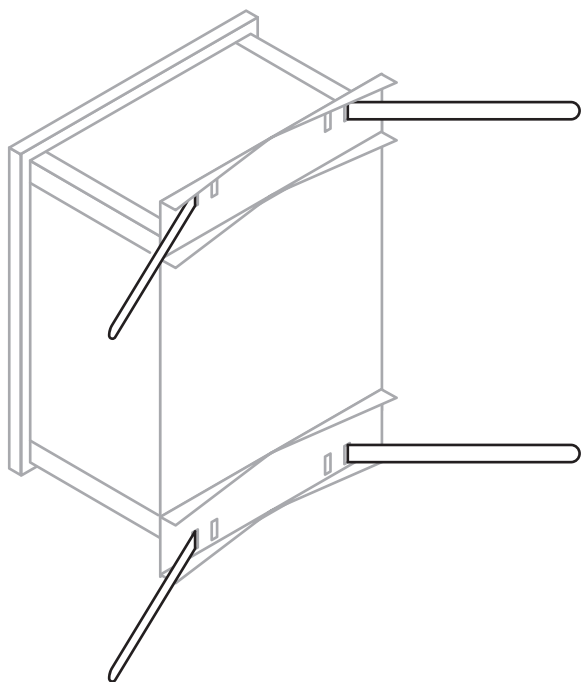

For large diameter poles

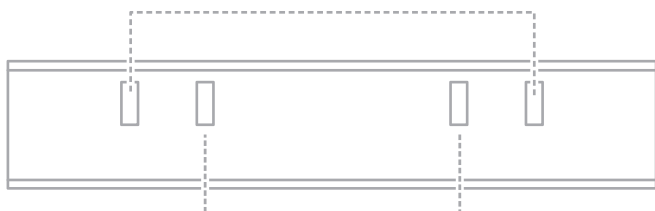

For small diameter poles

Installation

Step 2 Tighten each strap around pole using drill with 5/16 hex head driver bit.

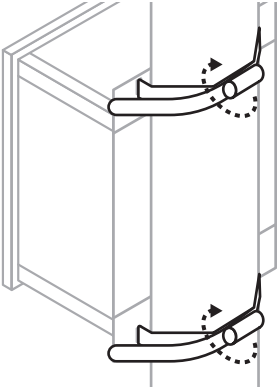

Step 3 Trim steel straps to desired length using tin snips.

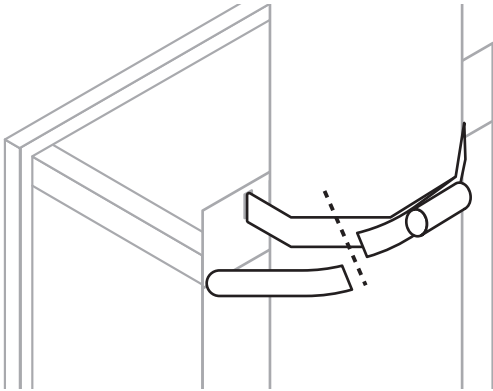

Wall Mounting

Notice: Exact camera model may not be shown. All cameras mount using same steps.

Camera

Step 1 Using chosen hardware (see “Preparing for Installation” section), secure camera mount to wall.

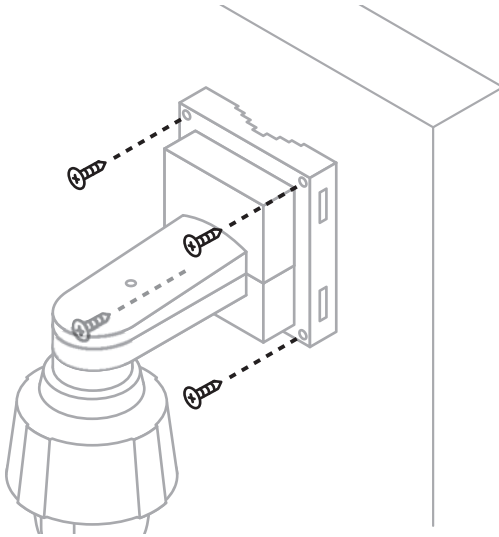

Step 2 Remove protective covering from camera.

Control Box

Step 1 Using chosen hardware (see “Preparing for Installation” section), secure control box to wall.

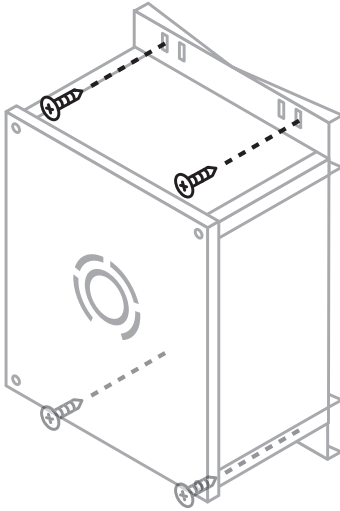

Connecting

Step 1 Twist protective cap off either device input on bottom of control box. Cap should hang freely.

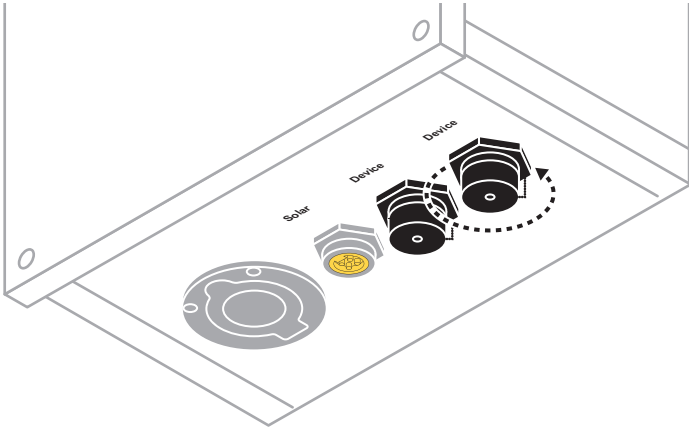

Step 2 Plug connector coming from camera into input. Connector should snap firmly into place.

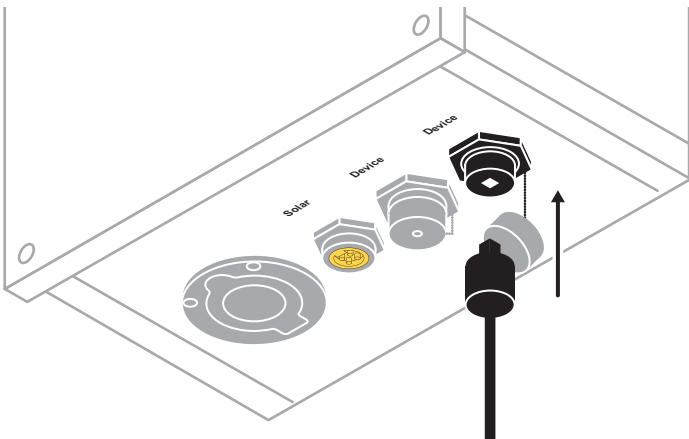

Installation

Step 3 Hand tighten protective cap on camera connector up into bottom of control box. This will create a watertight seal.

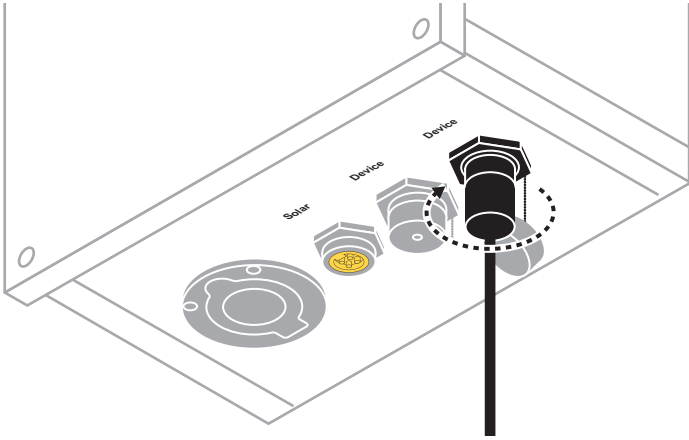

Warning: Do not use tools to tighten cap. Cap should be snug, but will not be flush against control box.

Powering

110V Power

Step 1 Plug cable end into 110V input on bottom of control box.

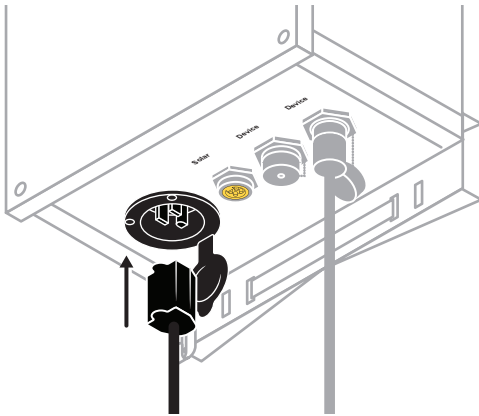

Step 2 Loop cable onto j-hook to create a drip loop.

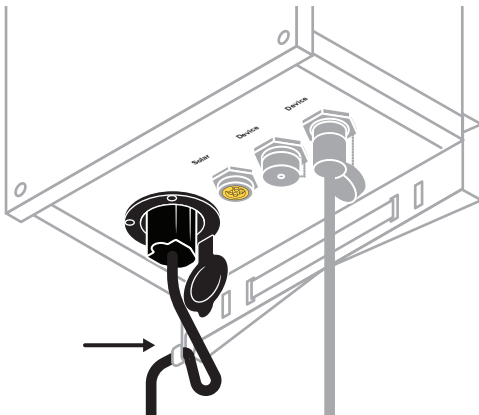

Installation

Step 3 Plug other side of cable into a 110V power outlet.

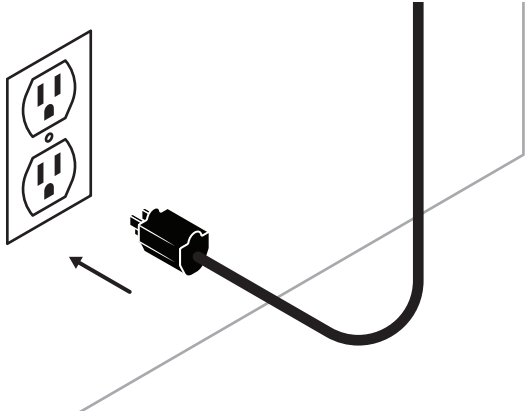

Solar Power

Proceed to your solar system manual for further instructions.

Camera Angling

Fixed Cameras

Step 1 Fully loosen screw on camera neck with a T-25 Allen wrench (included) to adjust camera angle.

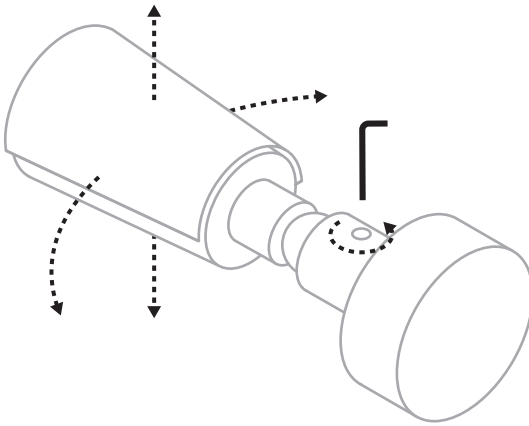

Step 2 Fully tighten screw on camera neck with Allen wrench when desired angle is chosen.

Verifying Camera Operation

After providing your TrueLook Camera with power, wait **10 minutes** for it to come online.

If you don't see the camera in the TrueLook Platform, contact Customer Support for assistance.

Maintenance Tips

- ✔ Clean camera lens as needed using a microfiber cloth.
- ✔ Mounting hardware may loosen over time due to construction machinery causing vibrations. Be sure to regularly check that all hardware has remained tight.

Troubleshooting

If something seems wrong with the system, it may be necessary to troubleshoot.

Camera Not Operating Properly

1. Check that the camera connector is securely fastened into the control box.
2. Check that the power source is supplying power.

If your system is still not functioning properly, please contact Customer Support for further assistance by emailing support@truelook.com or calling **833-878-3566 (Option 2)**.

Support Review

Once you're done with installation, snap a few pictures and email them to support@truelook.com. If our Customer Support team notices anything they can help with, they'll reach out. This will also help with a quick review of your setup if you run into future issues.

The Email

For the most efficient response from our team, include the following in your email:

1. Company name
2. Project name
3. Contact person for installation issues
4. The following photographs:
 - A. Your whole TrueLook solution: the camera, what it's mounted to, and any accessories
 - B. Close-ups of mounting
 - C. Close-ups of connections
 - D. Inside of battery enclosure (if applicable)