

Solar Package

Installation Manual

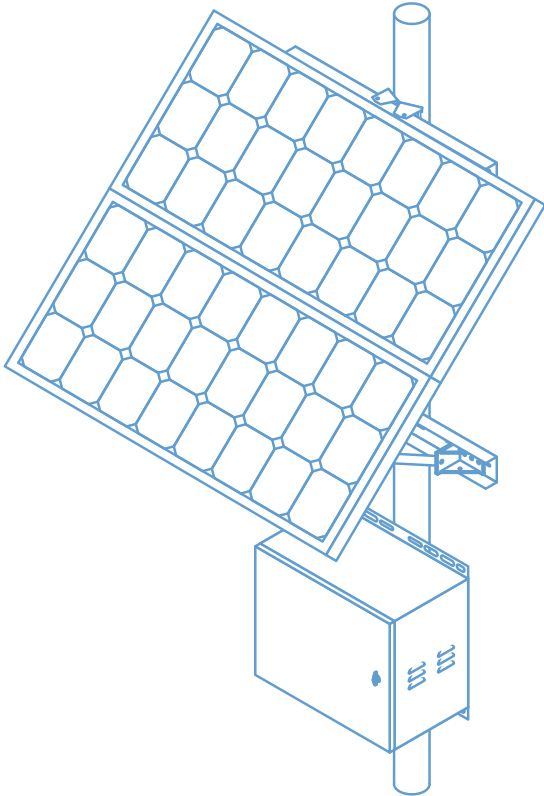

Assembled Unit

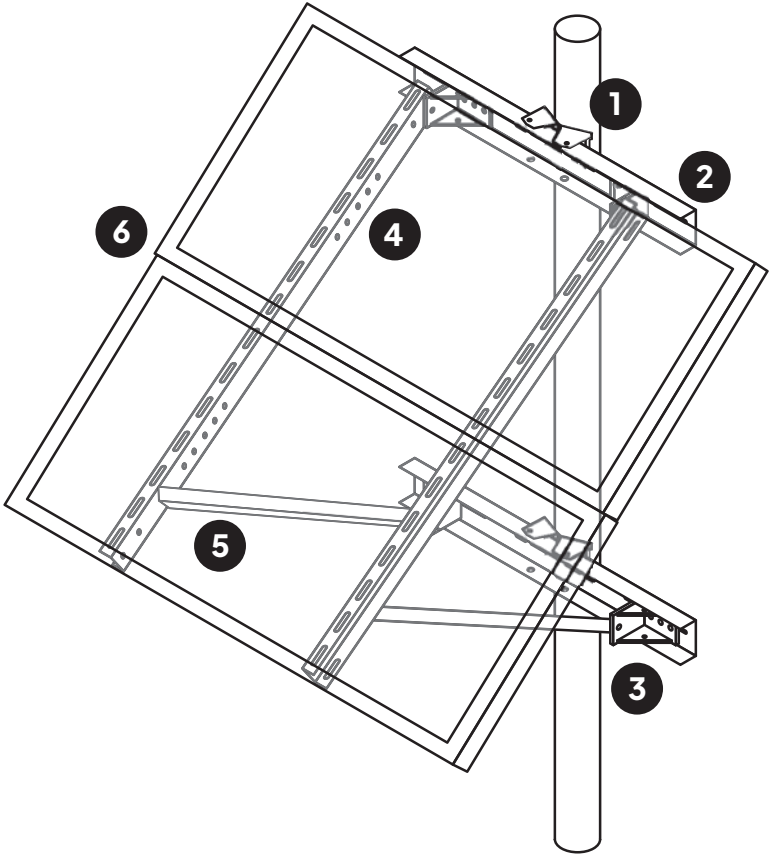

- 1. Mount bracket
- 2. Saddle bracket
- 3. L bracket
- 4. Side rail
- 5. Tilt leg
- 6. Solar panels

Unlimited Support

If you have any questions or issues with your TrueLook system, please don't hesitate to contact our Customer Support team.

Phone 833-878-3566 (Option 2)

Email support@truelook.com

You can also submit a support request online at:

support.truelook.com/contact-support

Online Resources

Visit truelook.com/install to access:

- ✔ A guide to administrative settings and time-lapse setup
- ✔ Video demonstrations of installation procedures
- ✔ And more!

For Terms & Conditions, as well as Warranty information, visit: truelook.com/terms-conditions.

Hardware Packing List

Solar Panels [2x]

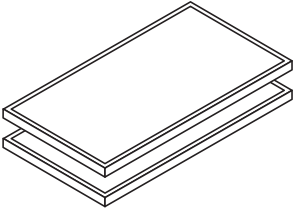

Connectors

3-to-1 Connectors [2x]

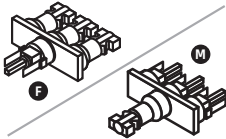

20' Panels to Battery Enclosure Cable [1x]

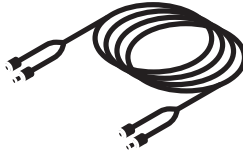

Load Connector [1x]



Battery Backup System

Number of batteries varies based on solar model.

Batteries [2-4x]

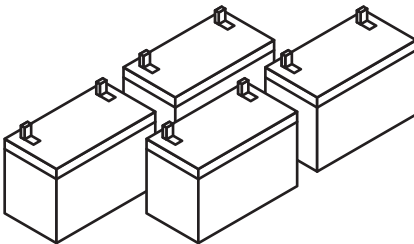

Enclosure [1x]

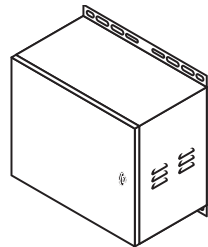

Getting Started

Mounting Hardware

Mount Brackets [2x]

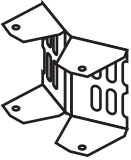

Steel Straps [4x]

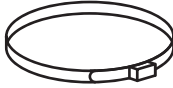

L Brackets [4x]

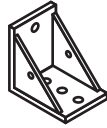

Saddle Brackets [2x]

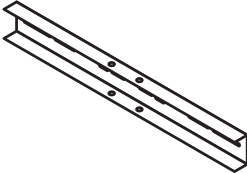

Side Rails [2x]

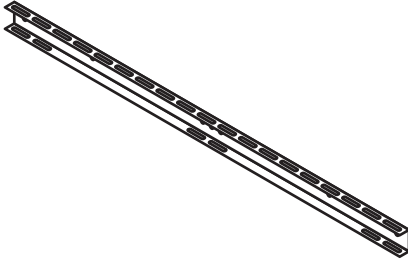

Tilt Legs [2x]

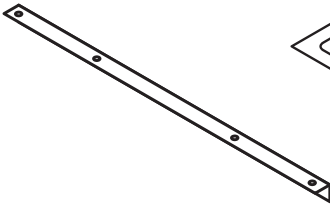

Anti-Seize Packet [1x]

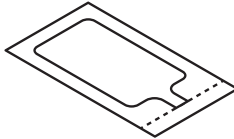

Assorted Hardware

5/16" bolts



5/16" nuts



1/4" bolts



1/4" nuts



Preparing for Installation

Solar Panel Positioning

Warning: Failure to observe all following requirements may result in system downtime. Units self-recover automatically once panels receive sufficient sunlight.

Step 1 Ensure panels will face **due south**.

The chosen mounting location should allow the panels to face the equator (**directly south**) in order to capture adequate sunlight and properly charge.

Step 2 Determine your panels' angle.

Refer to the chart on the following page to find the proper angle for your solar panels based on your state.

Step 3 Ensure panels remains unobstructed.

Panels must receive direct sunlight throughout the day. Do not let trees, equipment, structures, or anything else block the sun.

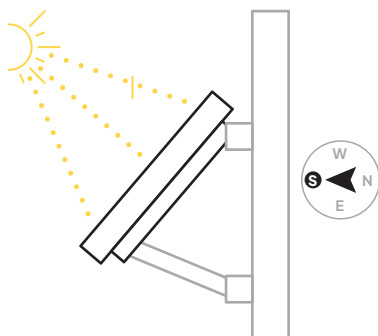

Panel Angles by State

Alabama	45°	New Hampshire	65°
Alaska	80°	New Jersey	65°
Arizona	45°	New Mexico	45°
Arkansas	60°	New York	65°
California	45°	North Carolina	60°
Colorado	55°	North Dakota	70°
Connecticut	60°	Ohio	60°
Delaware	65°	Oklahoma	50°
District of Col.	60°	Oregon	65°
Florida	45°	Pennsylvania	65°
Georgia	55°	Rhode Island	65°
Hawaii	40°	South Carolina	55°
Idaho	65°	South Dakota	65°
Illinois	65°	Tennessee	60°
Indiana	65°	Texas	45°
Iowa	65°	Utah	65°
Kansas	65°	Vermont	65°
Kentucky	60°	Virginia	60°
Louisiana	45°	Washington	65°
Maine	65°	West Virginia	60°
Maryland	60°	Wisconsin	65°
Massachusetts	65°	Wyoming	65°
Michigan	65°		
Minnesota	65°		
Mississippi	45°		
Missouri	60°		
Montana	70°		
Nebraska	65°		
Nevada	65°		

Determine Mounting Hardware

Pole Mounting

Your panel mounting kit includes steel straps for pole mounting. For jobsites that experience extreme wind conditions, we suggest using one of the following hardware options in their place:

- ✓ U bolts
- ✓ Lag bolts
- ✓ Through bolts

When using any of these alternatives, discard the mount brackets and place chosen bolts directly into the saddle brackets.

Wall Mounting

Your panel mounting kit **does not include** hardware for wall mounting. Choose appropriate mounting hardware for your surface.

Battery Enclosure Mounting

Your battery enclosure **does not include** hardware for pole or wall mounting.

- ✓ For pole mounting, choose two steel straps that are rated for 500 lbs in total.
- ✓ For wall mounting, choose the appropriate mounting hardware for your surface. Lag bolts and U bolts are recommended.

Mounting Hardware

Pole Mounting

Warning: Wear protective work gloves throughout installation process. Solar panels and other hardware pieces have sharp edges.

Step 1 Secure one mount bracket to pole at maximum desired height using two steel straps. Tighten each strap around pole using a drill with a 5/16" hex head driver bit (not included) and trim steel straps to desired length using tin snips (not included).

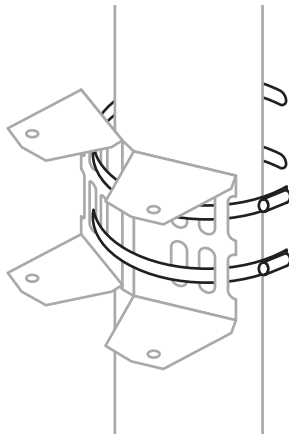

Installation

Step 2 Secure one saddle bracket to mount bracket using 5/16" hardware.

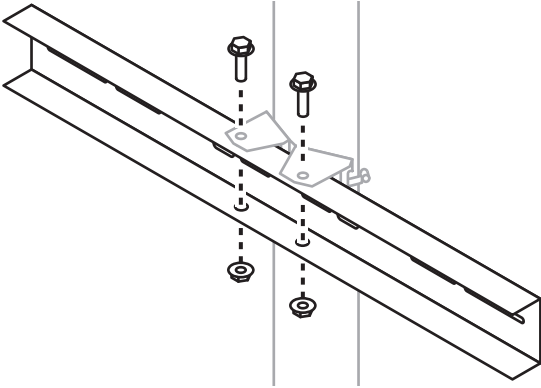

Step 3 Secure lower mount bracket to pole using previous method. Do not fully tighten bracket to pole.

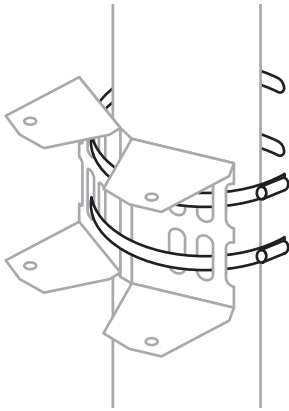

Installation

Step 4 Secure lower saddle bracket to mount bracket using 5/16" hardware.

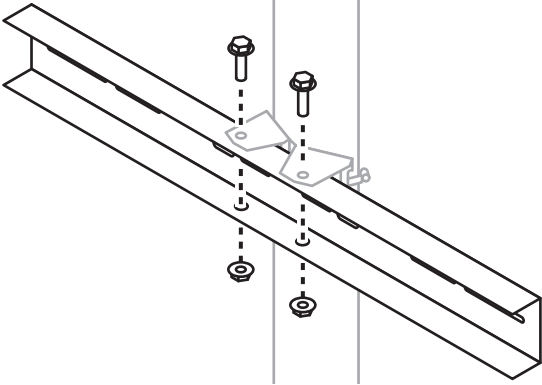

Step 5 Adjust lower hardware so saddle brackets are necessary distance apart for needed angle degree (see chart), then fully tighten lower mount bracket to pole.

Angle	Double Panel Rail (61 in)
30°	38 in
45°	49.5 in
60°	67 in

A technical line drawing showing the same rail and pole assembly as in Step 4. Dashed arrows indicate the vertical movement of the lower saddle bracket to adjust the angle of the rail. The rail is shown at a downward angle.

Installation

Step 6 Lay side rails on solar panel holes to estimate upper L bracket spacing. Measure between inside of rails for accuracy.

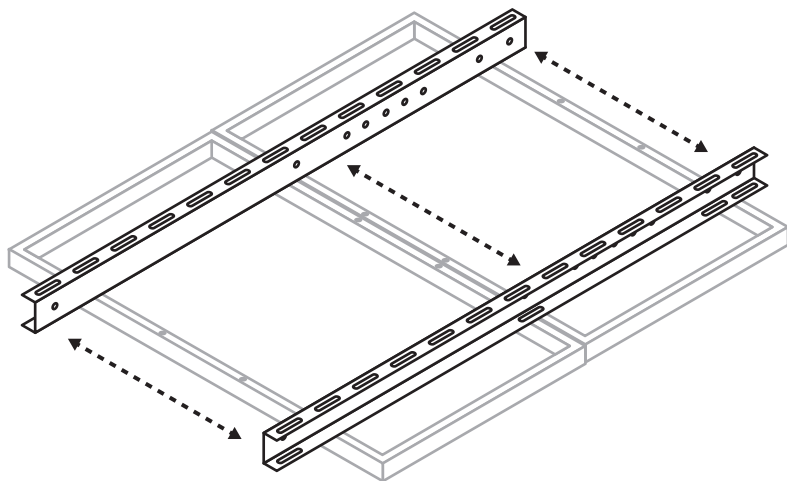

Step 7 Attach L brackets to upper and lower saddle brackets using 5/16" hardware. Lower L brackets face outward, and upper L brackets face inward.

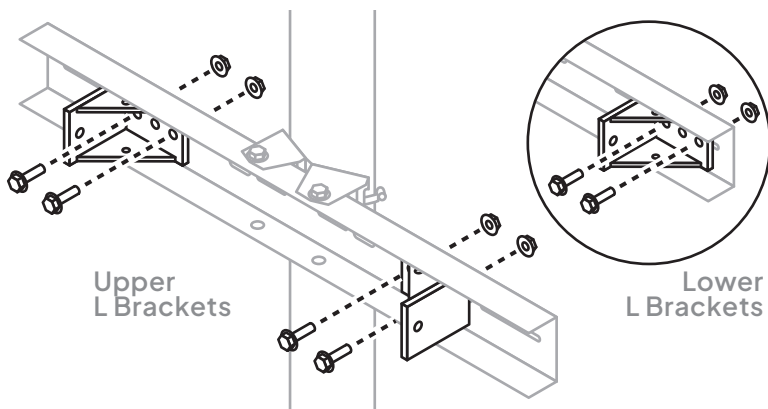

Installation

Step 8 Secure side rails to exterior of L brackets on upper saddle bracket using 5/16" hardware.

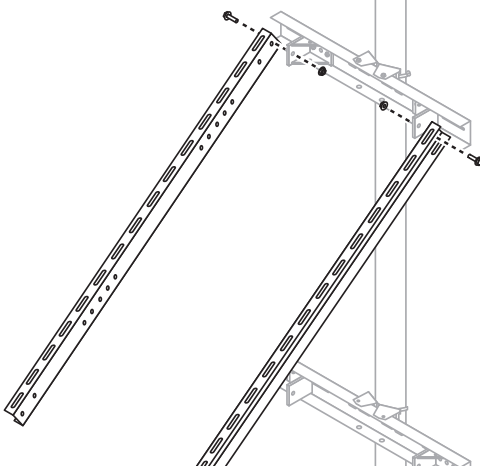

Step 9 Attach tilt legs to interior of L brackets on lower saddle bracket using 5/16" hardware.

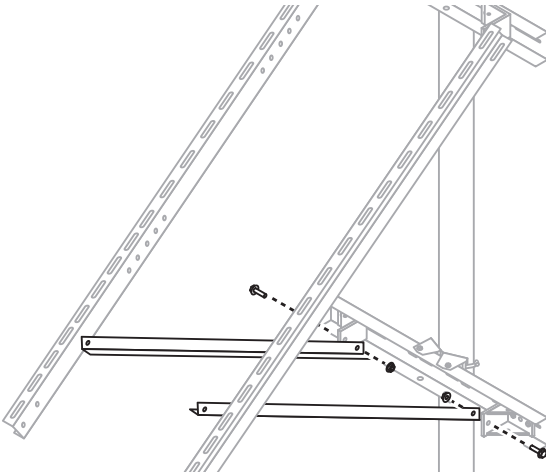

Installation

Step 10 Secure tilt legs to side rails using 5/16" hardware.

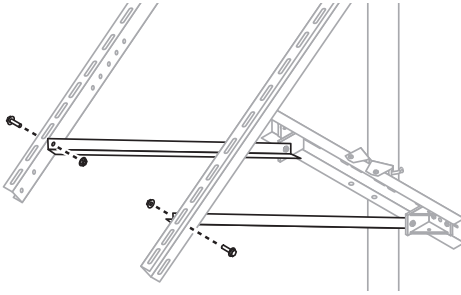

Step 11 Check all bolts are securely tightened.

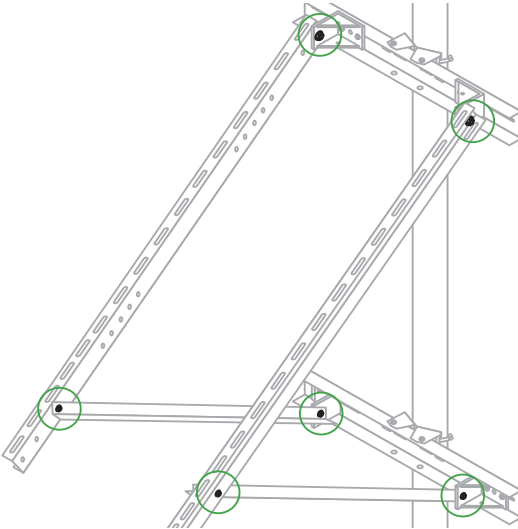

Step 12 Using disposable gloves, carefully apply anti-seize to all nuts and bolts.

Wall Mounting

Warning: Wear protective work gloves throughout installation process. Solar panels and other hardware pieces have sharp edges.

Step 1 Set aside mount brackets, as these aren't needed for wall mounting.

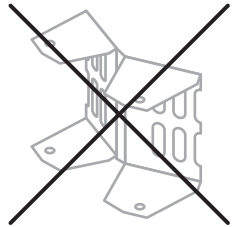

Step 2 Lay side rails on solar panel holes to estimate upper L bracket spacing. Measure between inside of rails for accuracy.

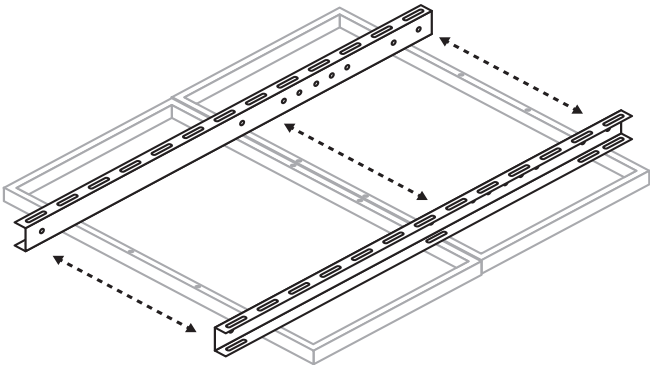

Installation

Step 3 Attach L brackets to upper and lower saddle brackets using 5/16" hardware. Lower L brackets face outward, and upper L brackets face inward.

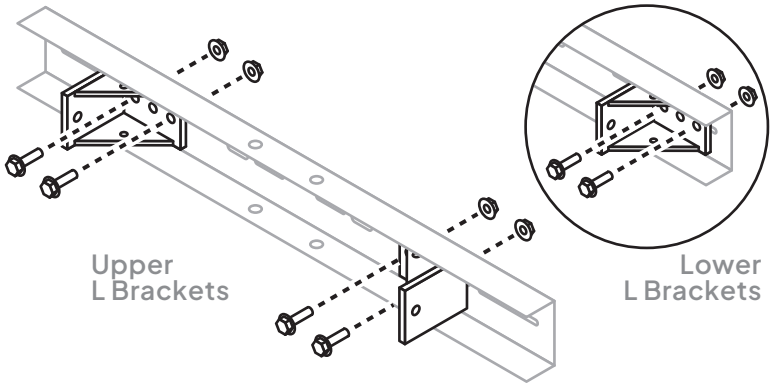

Step 4 Using appropriate mounting hardware for your surface, secure upper saddle bracket directly to wall at maximum desired height.

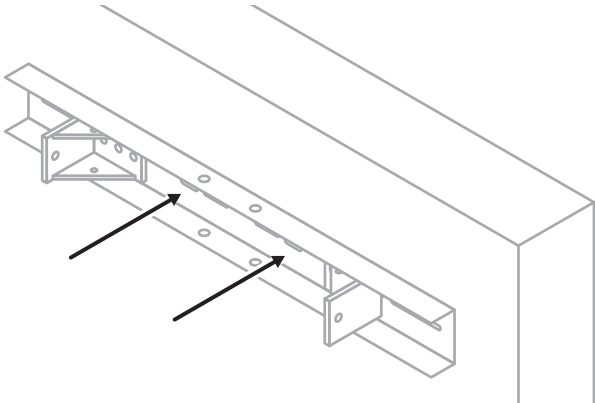

Installation

Step 5 Measure necessary distance downward for needed angle degree (see chart), then secure lower saddle bracket directly to wall using appropriate mounting hardware for your surface.

Angle	Double Panel Rail (61 in)
30°	38 in
45°	49.5 in
60°	67 in

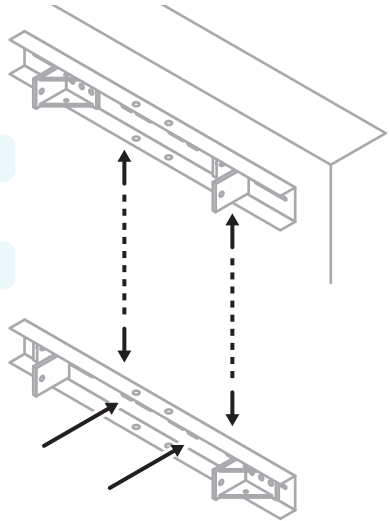

To complete assembly, follow pole mounting steps 8–12.

Solar Panels

Step 1 Secure solar panels to side rails using 1/4" hardware.

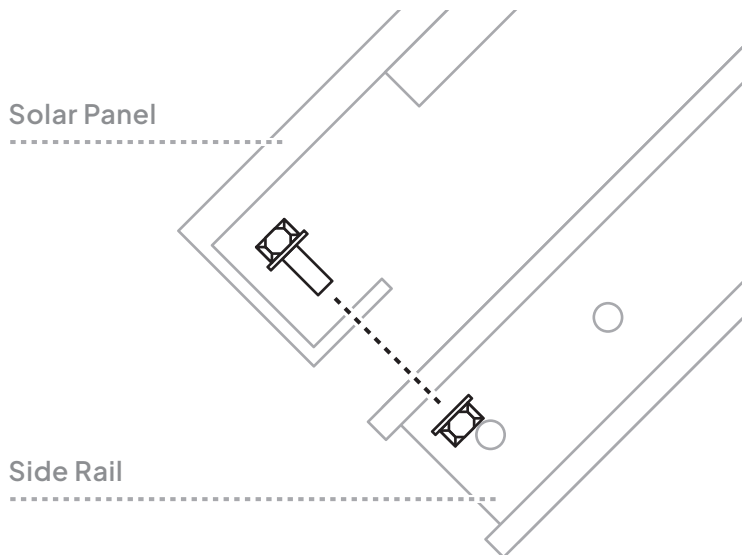

Step 2 Using disposable gloves, carefully apply anti-seize to nuts and bolts.

Battery Enclosure

Step 1 Determine mounting location. It's recommended to mount battery enclosure at ten feet high or lower for maintenance purposes.

Step 2 Using chosen hardware (see "Preparing for Installation" section), secure battery enclosure to pole or wall.

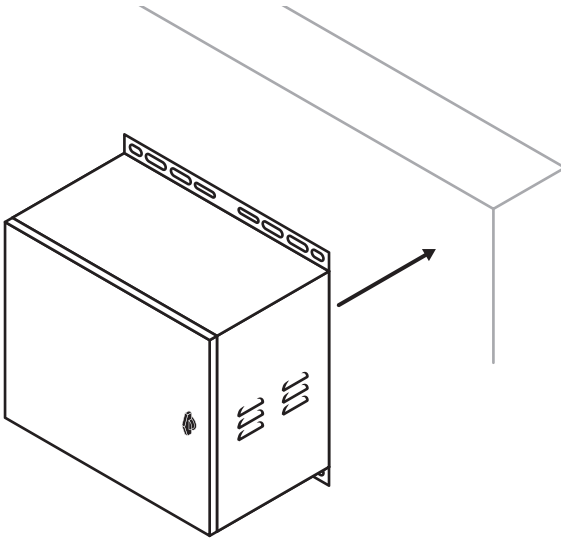

Installation

Step 3 Carefully place batteries into battery enclosure.

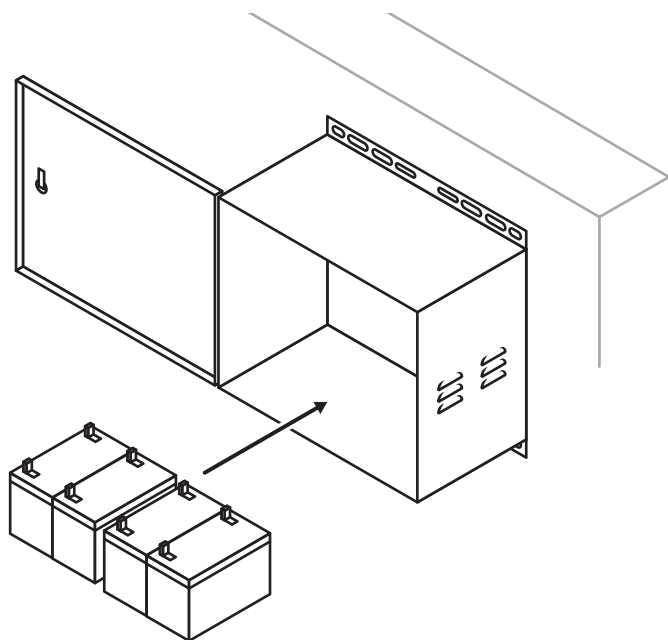

Optional: For extra security, add a padlock (not provided) to enclosure handle.

Batteries Installation

Two Batteries Wiring

Warning: Never connect red to black. Batteries are wired parallel for 12VDC.

Step 1 Snap the positive (red) battery cable to the positive (red) connector on **Battery A**.

Step 2 Snap the negative (black) battery cable to the negative (black) connector on **Battery B**.

Step 3 Snap the positive (red) connector on **Battery A** to the positive (red) connector on **Battery B**.

Step 4 Snap the negative (black) connector on **Battery A** to the negative (black) connector on **Battery B**.

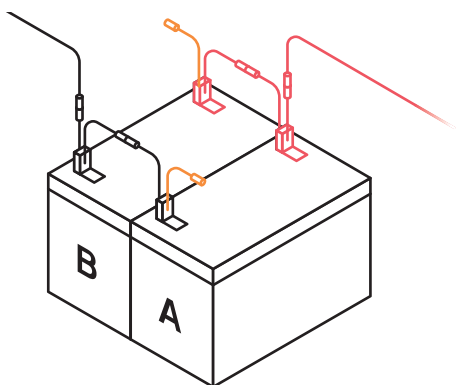

Notice: There will be an unused set of connections (highlighted in orange).

Four Batteries Wiring

Warning: Never connect red to black. Batteries are wired parallel for 12VDC.

Step 1 Take the four positive (red) wires coming from the distribution block and connect them to the positive (red) connectors coming from each battery.

Step 2 Take the four negative (black) wires coming from the distribution block and connect them to the negative (black) connectors coming from each battery.

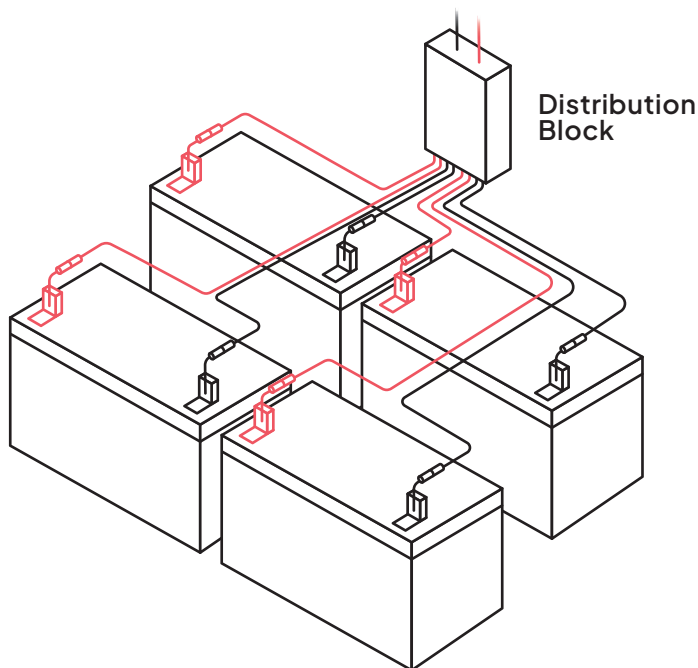

Connecting Camera to Battery Enclosure

Step 1 Proceed to your camera system's manual for instructions on how to:

- A. Mount camera system and control box
- B. Connect camera system to control box

Step 2 Connect camera system's control box to power by aligning notches and plugging one end of load connector into control box solar input. Gently hand tighten to screw silver collar into input.

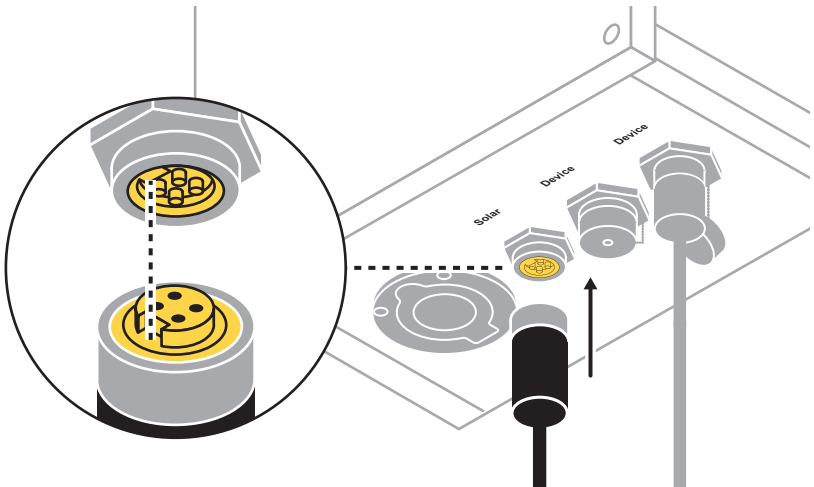

Warning: Never use tools to tighten connectors. This may result in over tightening and could break connector.

Connecting & Powering

Step 3 Loop cable onto control box j-hook to create a drip loop.

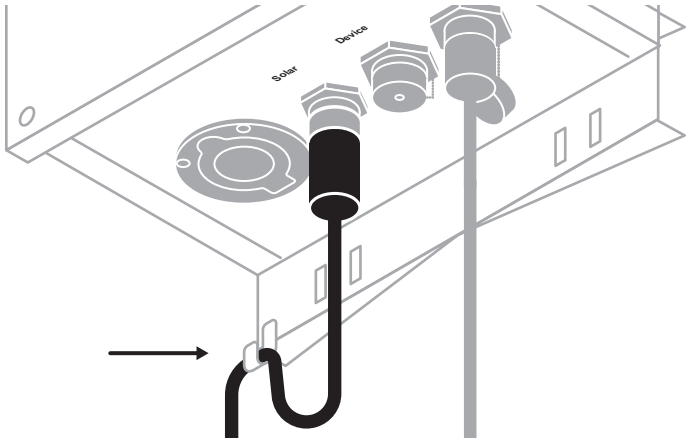

Step 4 Repeat step 2 to connect other end of load connector into input located on bottom of battery enclosure.

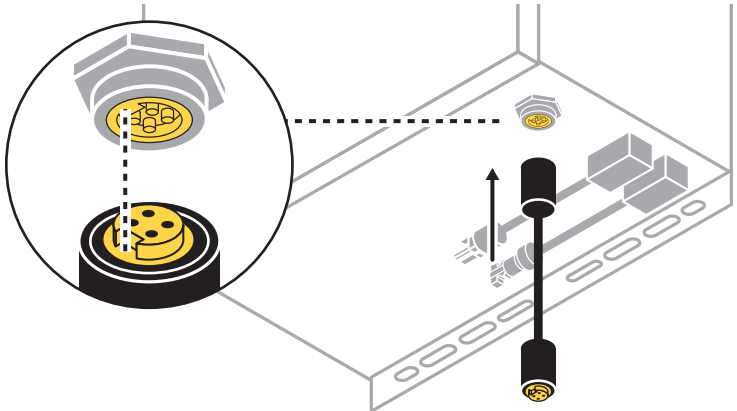

Connecting & Powering

Step 5 Open battery enclosure and flip on breakers CB1 and CB2.

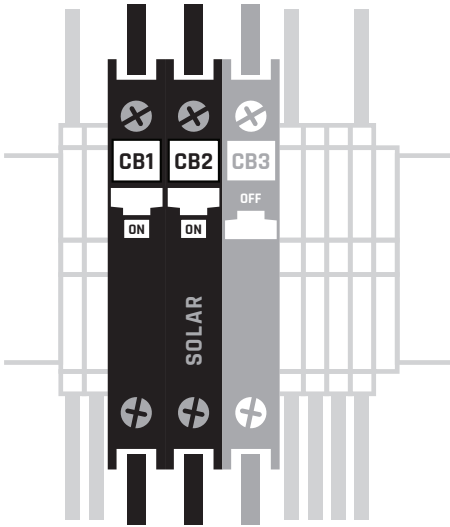

Connecting Solar Panels to Battery Enclosure

Warning: You should not need to force connectors together.

Step 1 Each solar panel has two short cables coming from them with one male connector end and one female connector end.

Plug the female connector ends into the two open ports on the female 3-to-1 connector and the male connector ends to the two open ports on the male 3-to-1 connector. There will be one port on each 3-to-1 connector that will not be used.

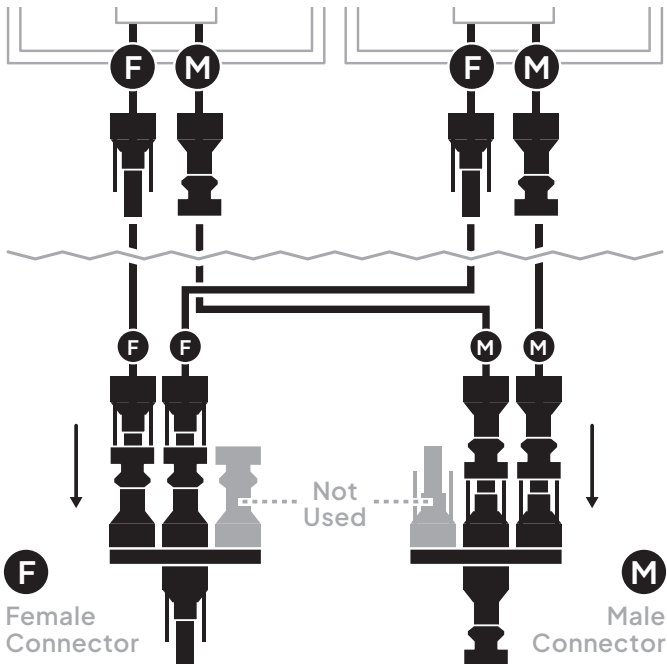

Connecting & Powering

Step 2 Connect one end of the 20' cable to the single connection sides of their respective 3-to-1 connectors.

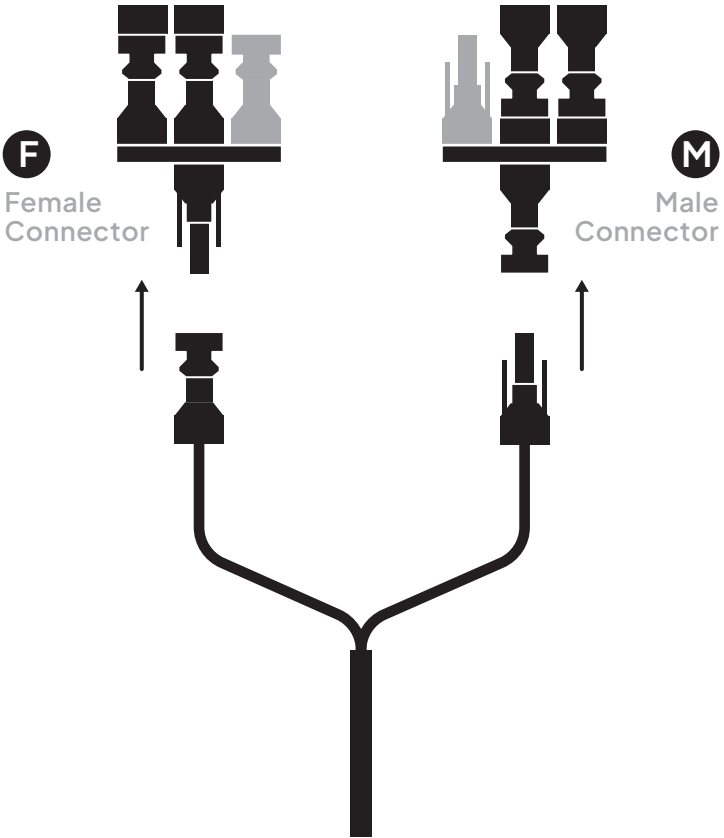

Connecting & Powering

Step 3 Connect the other end of the 20' cable to their respective connector ends coming from the battery enclosure.

The connectors are positive locking mechanisms, and each pair is keyed differently to ensure they are connected properly.

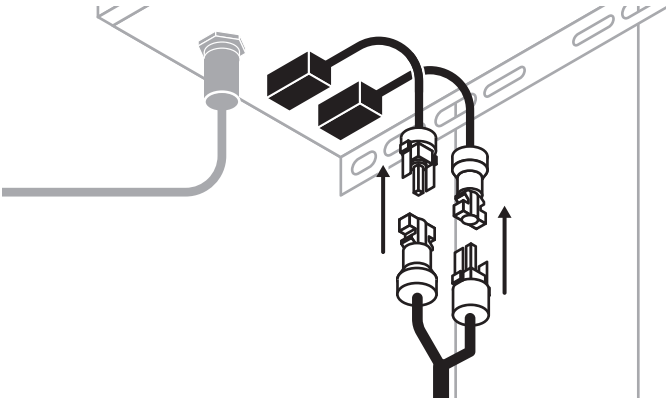

Step 4 Flip on breaker CB3.

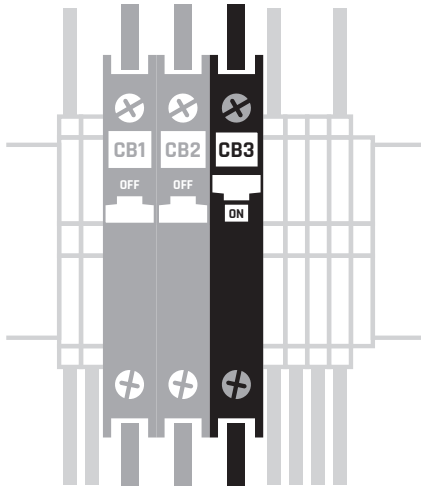

Confirming System Power

Step 1 Verify the panel is charging the unit. With sunlight, the leftmost LED on the ProStar unit will turn green within 5 minutes after powering.

- ✓ A yellow LED lit on the ProStar unit means your panels are not receiving sunlight, and the camera is running on battery power.
- ✓ A red LED lit on the ProStar unit means there is an issue with your system. Please contact TrueLook Support.

Step 2 Verify that the following numbers are displayed on the ProStar's digital readout. You may need to cycle left/right using the arrows to get to the pictured screen.

Solar Amps ☀️

0.5 - 4+

Battery 🔋

12 - 14+

Load Amps ⚡️

0.3 - 0.7

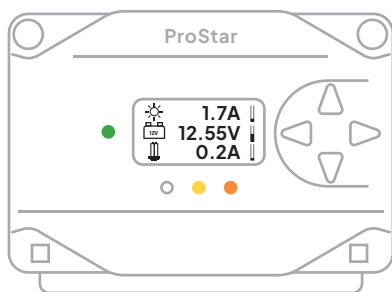

If numbers are displayed correctly, the system should be fully functioning at this stage.

Connecting & Powering

Step 3 Verify that there are two green LED lights on the EMC-1 unit.

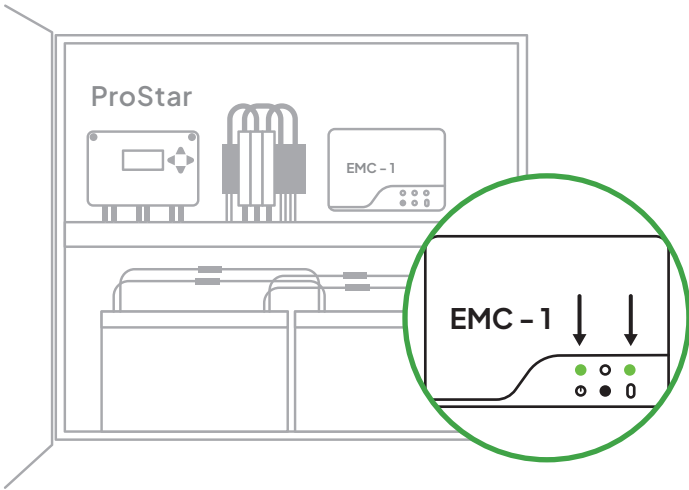

Troubleshooting

If something seems wrong with the system, it may be necessary to troubleshoot.

Cautions:

- Troubleshooting should be attempted by qualified personnel only.
- A battery can cause serious damage if shorted.
- Do not disassemble the ProStar from its case. There are no user serviceable parts inside the ProStar.

Camera Not Operating Properly

1. Check that the load breaker is turned on.
2. Check that the camera cable connectors are securely fastened.
3. If the ProStar internal temperature is above 80°C/176°F, the load will be disconnected, and all LEDs will be flashing in sequence. Check that nothing is obstructing the vents at the top of the case to ensure clear airflow around the ProStar.

Battery Is Not Charging

1. Check that all wire connections in the system are correct and tight.

If your system is still not functioning properly, please contact TrueLook Support for further assistance.

Maintenance Tips

- ✔ Do not allow smoking or open flames near the battery enclosure.
- ✔ If a battery has been unused for a long time, charge it externally with a battery charger prior to using it again for maximum efficiency.
- ✔ Solar panels are designed to quickly melt snow on their own. If there is a more urgent need to remove snow, gently use a soft brush. Using too much force may scratch or damage the panels.
- ✔ If the solar panels need cleaning, use only water and a microfiber cloth.
- ✔ Do not store any system components on the ground to avoid the intrusion of water or dirt.

Battery Replacement

We recommend the **Duracell Ultra Platinum AGM BCI Group 31M Deep Cycle Marine & RV Battery** as a replacement.

If you are unable to find this specific battery, the battery should meet the following specifications:

Product Category: Marine/RV	Capacity: 105AH
Voltage: 12	Capacity 20hr: 105AH
Format: BCI Group 31M	Cranking Amps: 1000
Chemistry: Lead Acid	Cold Cranking Amps: 800
Lead Acid Type: Deep Cycle, Dual Purpose (Starting/Cycling)	Marine Cranking Amps: 1000
Lead Acid Design: AGM	Terminal Type: DT, SAE/M8 Stud, SAE/M8 Threaded Post, WNT

Support Review

Did you know that our support team offers a free installation review?

Once you're done, simply snap a few pictures and email them to support@truelook.com. If we notice anything that we can help with, we'll reach out. This will also help our support team quickly view your setup if you run into equipment issues at any point in the future.

The Email

For the most efficient response from our team, include the following in your email:

1. Company name
2. Project name
3. Contact person for installation issues
4. The following photographs:
 - A. Your whole TrueLook solution: the camera, what it's mounted to, and any accessories
 - B. Close-ups of mounting
 - C. Close-ups of connections
 - D. Inside of battery enclosure