

# TrueDeter Fixed

---

## Installation Manual

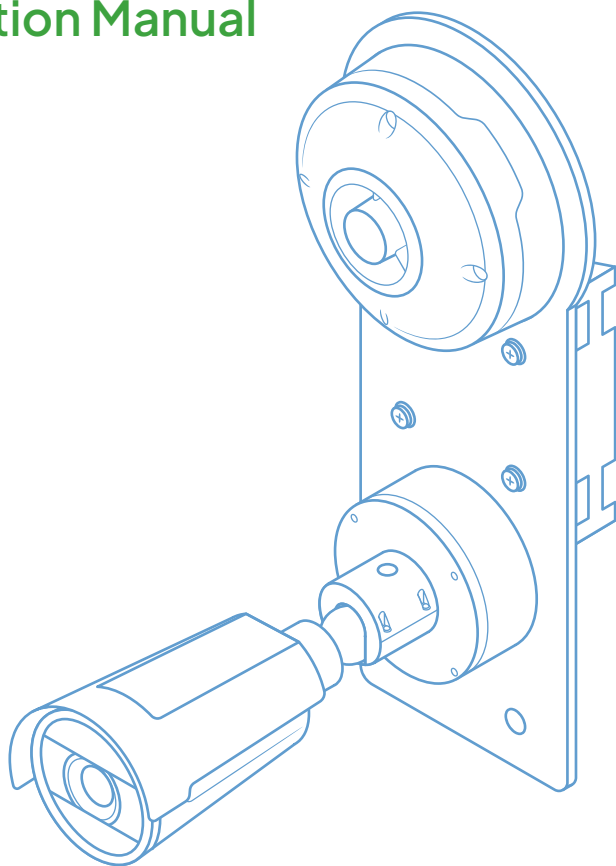

# Assembled Unit

---

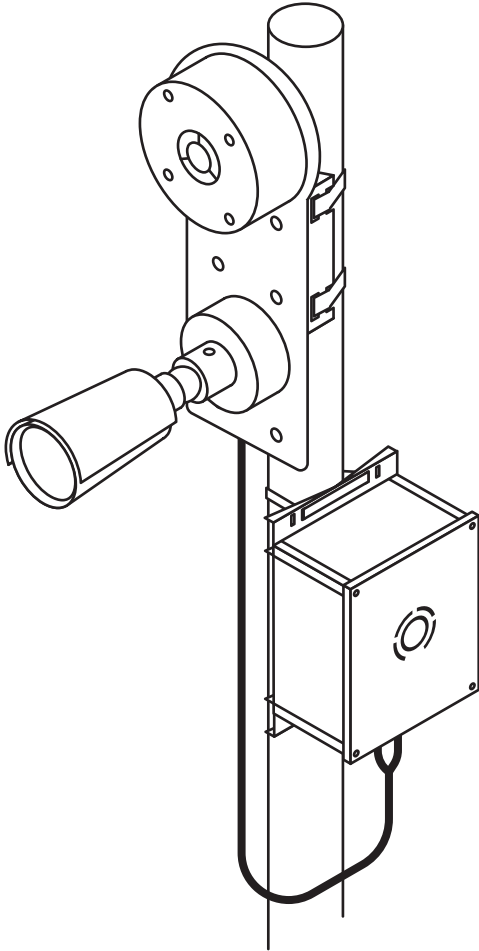

# Unlimited Support

---

If you have any questions or issues with your TrueLook system, please don't hesitate to contact our Customer Support team.

**Phone** 833-878-3566 (Option 2)

**Email** [support@truelook.com](mailto:support@truelook.com)

You can also submit a support request online at:

[support.truelook.com/contact-support](https://support.truelook.com/contact-support)

## Online Resources

---

Visit [truelook.com/install](https://truelook.com/install) to access:

- ✔ A guide to administrative settings and time-lapse setup
- ✔ Video demonstrations of installation procedures
- ✔ And more!

For Terms & Conditions, as well as Warranty information, visit: [truelook.com/terms-conditions](https://truelook.com/terms-conditions).

# Hardware Packing List

---

Camera System [1x]

---

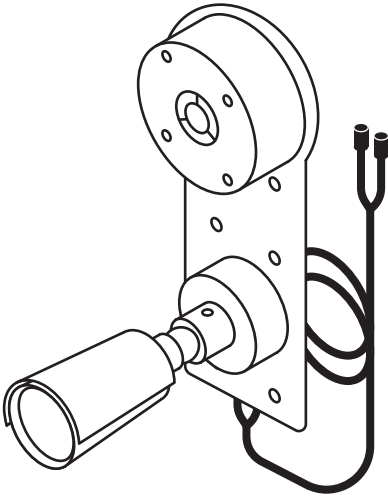

Control Box [1x]

---

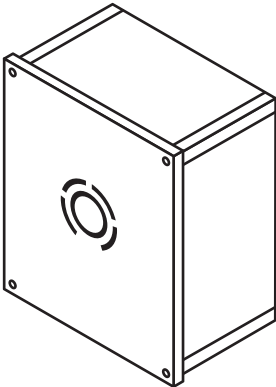

## Getting Started

### Pole Mounting Hardware

---

Steel Straps [4x]

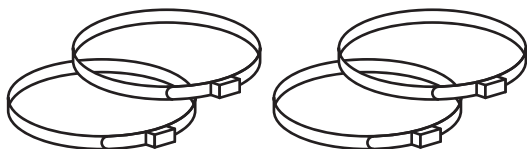

### Wall Mounting Hardware

---

L Brackets [4x]

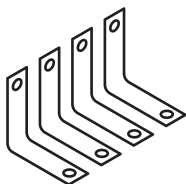

Screws [4x]



Flat Washers [4x]



Lock Washers [4x]



Nuts [4x]

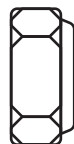

### Assorted Hardware

---

Allen Wrench [1x]

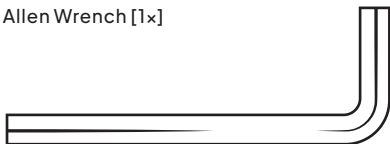

**Warning:** This equipment contains flashing lights, which may induce epileptic seizures in at-risk individuals.

# Pole Mounting

---

## Camera System

**Step 1** Thread steel straps through top and bottom of pole mount on back of plate.

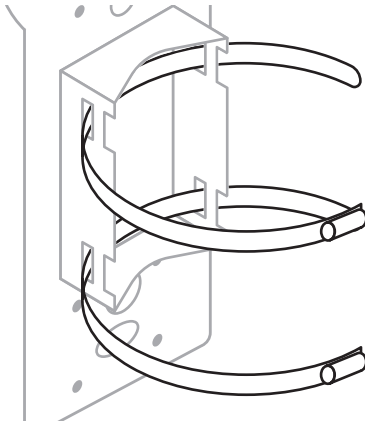

**Step 2** Tighten each strap around pole using drill with 5/16 hex head driver bit (not included).

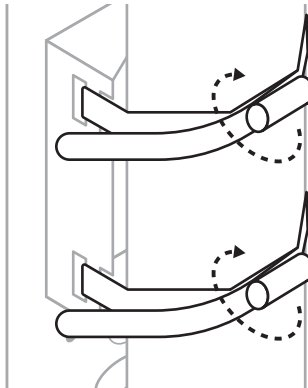

## Installation

**Step 3** Trim steel straps to desired length using tin snips (not included).

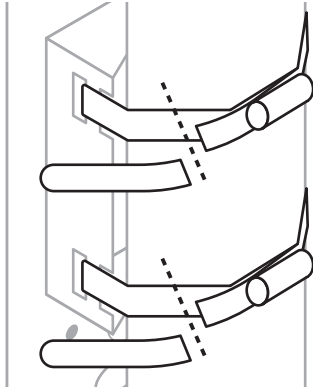

**Step 4** Loosen screw on camera neck with Allen wrench (included) to adjust camera angle. Tighten screw on camera neck with Allen wrench when desired angle is chosen.

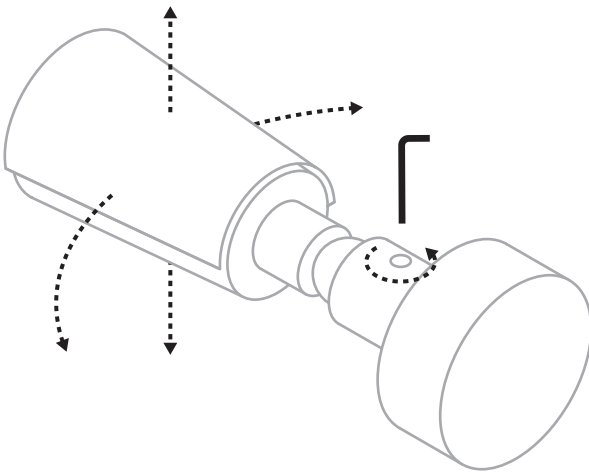

### Control Box

**Step 1** Thread steel straps through pole mounting hardware on top and bottom of control box.

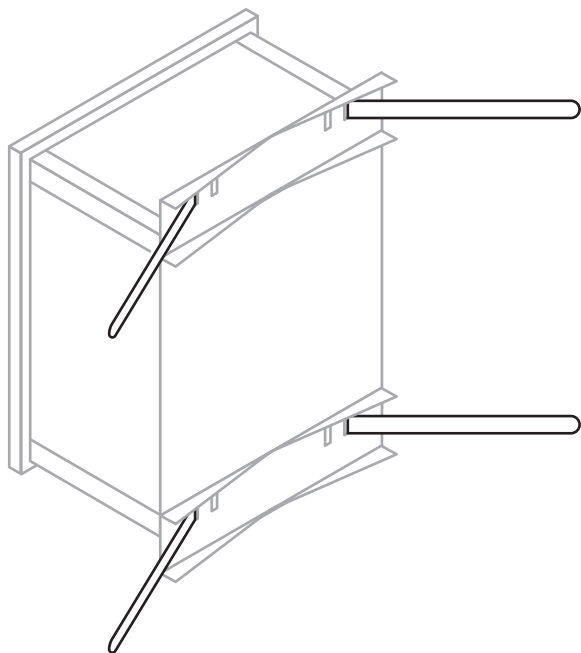

For large diameter poles

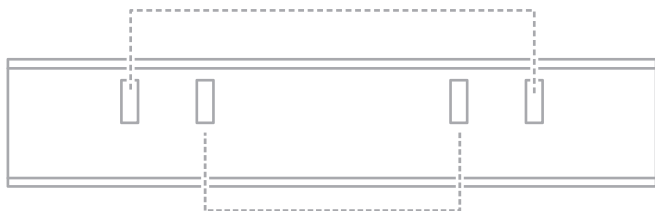

For small diameter poles



## Installation

**Step 2** Tighten each strap around pole using drill with 5/16 hex head driver bit.

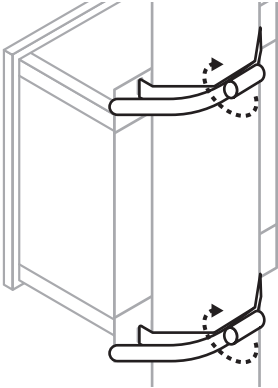

**Step 3** Trim steel straps to desired length using tin snips.

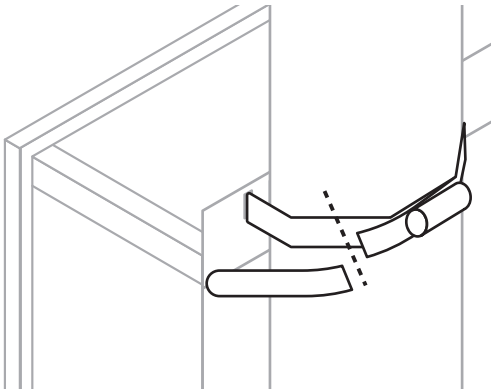

# Wall Mounting

## Camera System

**Step 1** Attach wall mounting hardware to sides of pole mount with screw, washer, lock washer, and nut, using drill with Phillips #2 bit (not included) on screws and pliers (not included) to hold nuts tight.

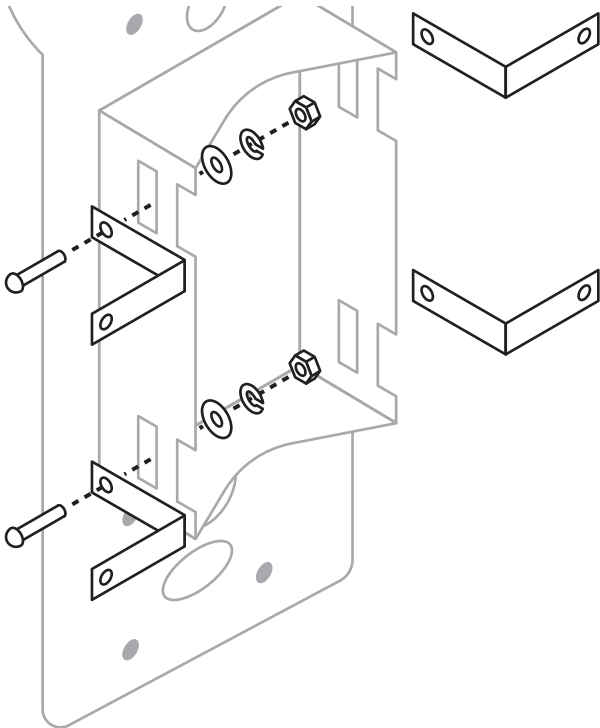

**Step 2** Using hardware appropriate for your mounting surface, attach camera to wall.

## Installation

**Step 3** Loosen screw on camera neck with Allen wrench (included) to adjust camera angle. Tighten screw on camera neck with Allen wrench when desired angle is chosen.

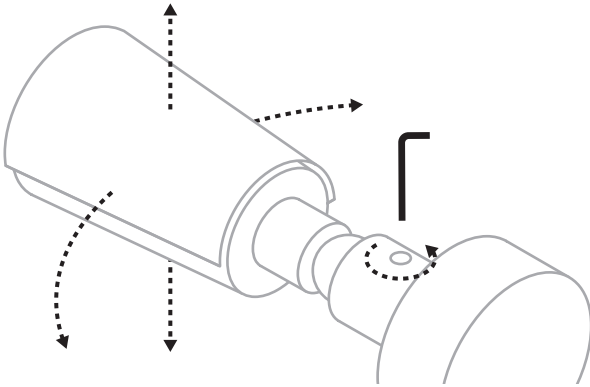

## Control Box

**Step 1** Using hardware appropriate for your mounting surface, secure control box to wall.

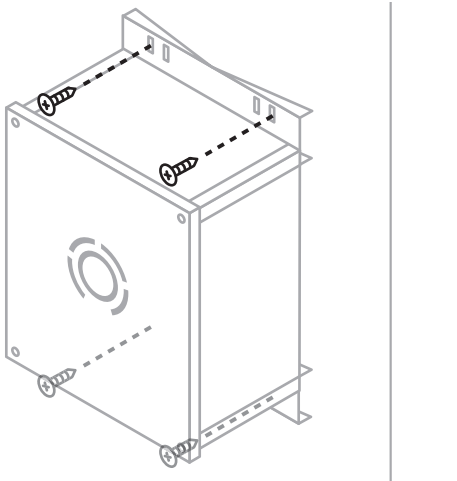

# Connecting

**Step 1** Twist protective caps off both device inputs on bottom of control box. Caps should hang freely.

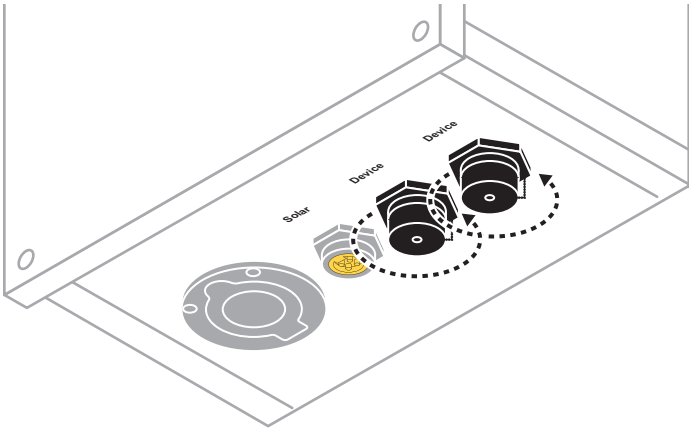

**Step 2** Plug connectors coming from camera into inputs. Connectors should snap firmly into place.

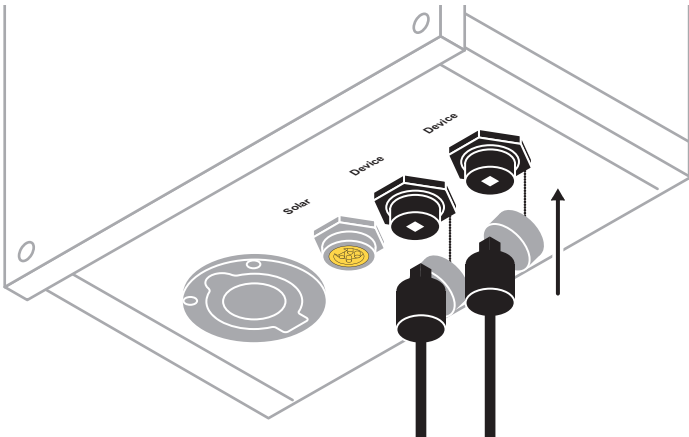

## Installation

**Step 3** Hand tighten protective caps on camera connectors up into bottom of control box. This will create a watertight seal.

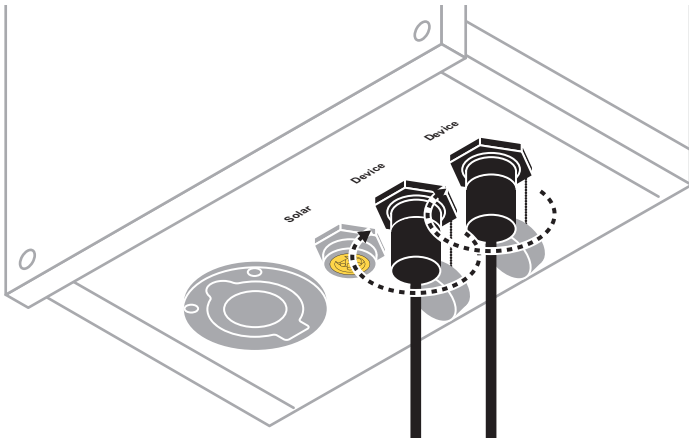

**Warning:** Do not use tools to tighten caps. Caps should be snug, but will not be flush against control box.

**Step 4** Remove protective covering from camera.

# Powering

## 110V Power

**Step 1** Plug cable end into 110V input on bottom of control box.

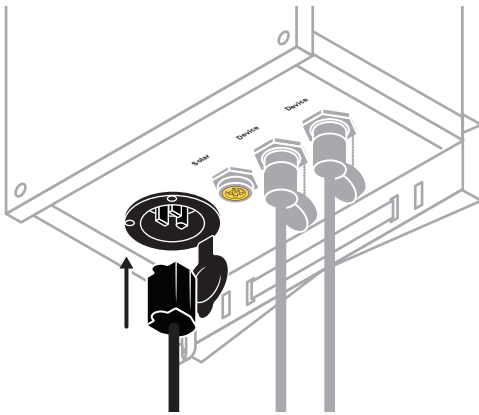

**Step 2** Loop cable onto j-hook to create a drip loop.

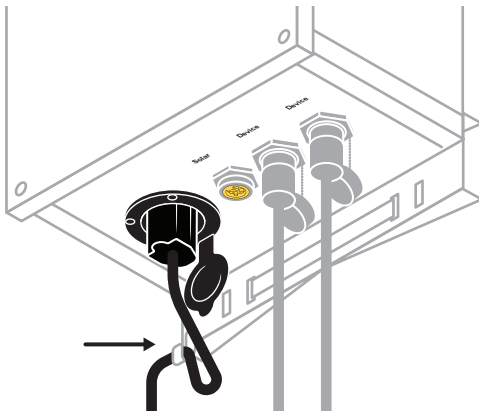

## Installation

**Step 3** Plug other side of cable into a 110V power outlet.

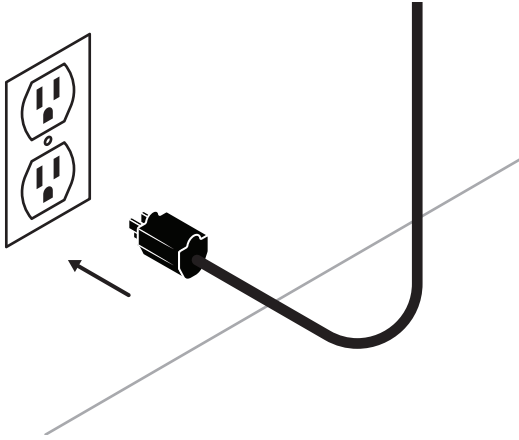

## Solar Power

Proceed to your solar system manual for further instructions.

# Verifying Camera Operation

---

After providing your TrueLook Camera with power, wait **10 minutes** for it to come online.

If you don't see the camera in the TrueLook Platform, contact Customer Support for assistance.

# Maintenance Tips

---

- ✔ Clean camera lens as needed using a microfiber cloth.
- ✔ Mounting hardware may loosen over time due to construction machinery causing vibrations. Be sure to regularly check that all hardware has remained tight.



# Troubleshooting

---

If something seems wrong with the system, it may be necessary to troubleshoot.

## Camera Not Operating Properly

1. Check that the camera cable connectors are securely fastened into the control box.
2. Check that the power source is supplying power.

If your system is still not functioning properly, please contact Customer Support for further assistance.

# Support Review

---

Once you're done with installation, snap a few pictures and email them to [support@truelook.com](mailto:support@truelook.com). If our Customer Support team notices anything they can help with, they'll reach out. This will also help with a quick review of your setup if you run into future issues.

## The Email

For the most efficient response from our team, include the following in your email:

1. Company name
2. Project name
3. Contact person for installation issues
4. The following photographs:
  - A. Your whole TrueLook solution: the camera, what it's mounted to, and any accessories
  - B. Close-ups of mounting
  - C. Close-ups of connections